

Safety of machinery
Equipment for power driven parking of motor vehicles
Safety and EMC requirements for design, manufacturing, erection and commissioning stages

La norma fornisce i requisiti tecnici per ridurre i rischi che si manifestano durante le fasi di installazione, funzionamento e manutenzione dei parcheggi automatici per i veicoli a motore permanentemente installati. Sono anche forniti i contenuti delle istruzioni per l'uso.

TESTO INGLESE

La presente norma è la versione ufficiale in lingua inglese della norma europea EN 14010:2003+A1 (edizione luglio 2009).

La presente norma sostituisce la UNI EN 14010:2004.

ICS 33.100.01; 53.020.99; 53.080

PREMESSA NAZIONALE

La presente norma costituisce il recepimento, in lingua inglese, della norma europea EN 14010:2003+A1 (edizione luglio 2009), che assume così lo status di norma nazionale italiana.

La presente norma è stata elaborata sotto la competenza della Commissione Tecnica UNI

Apparecchi di sollevamento e relativi accessori

Rispetto all'edizione precedente sono state aggiornate essenzialmente i riferimenti normativi e le tre appendici informative ZA, ZB e ZC.

La presente norma è stata ratificata dal Presidente dell'UNI ed è entrata a far parte del corpo normativo nazionale il 24 settembre 2009.

Le norme UNI sono elaborate cercando di tenere conto dei punti di vista di tutte le parti interessate e di conciliare ogni aspetto conflittuale, per rappresentare il reale stato dell'arte della materia ed il necessario grado di consenso.

Chiunque ritenesse, a seguito dell'applicazione di questa norma, di poter fornire suggerimenti per un suo miglioramento o per un suo adeguamento ad uno stato dell'arte in evoluzione è pregato di inviare i propri contributi all'UNI, Ente Nazionale Italiano di Unificazione, che li terrà in considerazione per l'eventuale revisione della norma stessa.

Le norme UNI sono revisionate, quando necessario, con la pubblicazione di nuove edizioni o di aggiornamenti.

È importante pertanto che gli utilizzatori delle stesse si accertino di essere in possesso dell'ultima edizione e degli eventuali aggiornamenti.

Si invitano inoltre gli utilizzatori a verificare l'esistenza di norme UNI corrispondenti alle norme EN o ISO ove citate nei riferimenti normativi.

English Version

**Safety of machinery - Equipment for power driven parking of
motor vehicles - Safety and EMC requirements for design,
manufacturing, erection and commissioning stages**

Sécurité des machines - Dispositif de stationnement
motorisé des véhicules automobiles - Exigences
concernant la sécurité et la CEM pour les phases de
conception, construction, montage et mise en service

Sicherheit von Maschinen - Kraftbetriebene
Parkeinrichtungen für Kraftfahrzeuge - Sicherheits- und
EMV-Anforderungen an Gestaltung, Herstellung,
Aufstellung und Inbetriebnahme

This European Standard was approved by CEN on 1 October 2003 and includes Amendment 1 approved by CEN on 19 June 2009.

CEN members are bound to comply with the CEN/CENELEC Internal Regulations which stipulate the conditions for giving this European Standard the status of a national standard without any alteration. Up-to-date lists and bibliographical references concerning such national standards may be obtained on application to the CEN Management Centre or to any CEN member.

This European Standard exists in three official versions (English, French, German). A version in any other language made by translation under the responsibility of a CEN member into its own language and notified to the CEN Management Centre has the same status as the official versions.

CEN members are the national standards bodies of Austria, Belgium, Bulgaria, Cyprus, Czech Republic, Denmark, Estonia, Finland, France, Germany, Greece, Hungary, Iceland, Ireland, Italy, Latvia, Lithuania, Luxembourg, Malta, Netherlands, Norway, Poland, Portugal, Romania, Slovakia, Slovenia, Spain, Sweden, Switzerland and United Kingdom.



EUROPEAN COMMITTEE FOR STANDARDIZATION
COMITÉ EUROPÉEN DE NORMALISATION
EUROPÄISCHES KOMITEE FÜR NORMUNG

Management Centre: Avenue Marnix 17, B-1000 Brussels

Contents

	Page
Foreword.....	3
Introduction	4
1 Scope	5
2 Normative references	6
3 Terms and definitions	8
4 List of significant hazards	10
5 Safety and EMC requirements and/or safety measures	16
5.1 General.....	16
5.2 Control devices and equipment used for safety purposes	16
5.3 Electrical equipment.....	22
5.4 Hydraulic systems and hydraulic equipment	23
5.5 Load carrier	25
5.6 Lifting elements	26
5.7 Transmission elements	29
5.8 Non-automatic horizontally moving parking equipment in areas accessible to the user.....	29
5.9 Safety devices for non-automatic horizontally moving parking equipment.....	31
5.10 Non-automatic vertically moving parking equipment in areas accessible to the user	31
5.11 Automatic parking equipment.....	32
5.12 Design of the transfer area	39
6 Verification of safety and EMC requirements and/or measures	40
6.2 Special verification	45
6.3 Type testing.....	46
7 Information for use	46
7.1 Instruction handbook	46
7.2 Marking	49
Annex A (normative) Design criteria	51
Annex B (informative) Automatic parking equipment	52
Annex C (normative) Design criteria	53
Annex ZA (informative) \square_{A1} Relationship between this European Standard and the Essential Requirements of EU Directive 98/37/EC \square_{A1}.....	55
Annex ZB (informative) \square_{A1} Relationship between this European Standard and the Essential Requirements of EU Directive 2006/42/EC \square_{A1}.....	56
Annex ZC (informative) \square_{A1} Relationship between this European Standard and the Essential Requirements of EU Directive 2004/108/EC \square_{A1}.....	57
Bibliography	58

Foreword

This document (EN 14010:2003+A1:2009) has been prepared by Technical Committee CEN /TC 98, "Lifting platforms", the secretariat of which is held by DIN.

This European Standard shall be given the status of a national standard, either by publication of an identical text or by endorsement, at the latest by January 2010, and conflicting national standards shall be withdrawn at the latest by January 2010.

This document includes Amendment 1, approved by CEN on 2009-06-19.

This document supersedes EN 14010:2003.

The start and finish of text introduced or altered by amendment is indicated in the text by tags $\boxed{A_1}$ $\triangleleft A_1$.

This document has been prepared under a mandate given to CEN by the European Commission and the European Free Trade Association, and supports essential requirements of EU Directive(s).



$\boxed{A_1}$ For relationship with EU Directive(s), see informative Annexes ZA, ZB and ZC, which are integral parts of this document. $\triangleleft A_1$

Annexes $\boxed{A_1}$ A and C $\triangleleft A_1$ are normative. Annex B is informative.

This document includes a Bibliography.

According to the CEN/CENELEC Internal Regulations, the national standards organizations of the following countries are bound to implement this European Standard: Austria, Belgium, Bulgaria, Cyprus, Czech Republic, Denmark, Estonia, Finland, France, Germany, Greece, Hungary, Iceland, Ireland, Italy, Latvia, Lithuania, Luxembourg, Malta, Netherlands, Norway, Poland, Portugal, Romania, Slovakia, Slovenia, Spain, Sweden, Switzerland and United Kingdom.

Introduction

 This European Standard is a type C standard as stated in EN ISO 12100-1:2003. 

The machinery concerned and the extent to which hazards, hazardous situations and events are covered are indicated in the scope of this document.

When producing this standard it was assumed that

- negotiation will take place between the manufacturer and the purchaser of the parking equipment/systems, concerning particular conditions for the use and places of use for the equipment/system, related to health, safety and environmental conditions;
- erection, commissioning and testing will be carried out by suitably trained persons;
- only legal drivers of vehicles will use the equipment/system;
- no vehicles in excess of the rated load or otherwise unsuitable (see clause 1), will use the equipment/system;
- persons will not be lifted or transported by the machinery;
- the machinery and its components will be kept in good repair and working order in accordance with the manufacturers instructions, to retain specified safety characteristics throughout the intended working life of the machinery;
- by design of the load bearing elements, safe operation of the machinery will be assured for loading ranging from zero to 100% of the rated capacities and during the loaded tests (see 6.1f);
- harmful materials, such as asbestos are not used as part of the machine;
- all parts of the equipment/system without specific requirements will be:
 - 1) designed in accordance with the usual engineering practice and design codes, using appropriate safety factors, taking account of all relevant forces, loads and failure modes;
 - 2) of sound mechanical and electrical construction;
 - 3) made from materials of adequate strength and durability and of suitable quality for their intended purpose.

When provisions of this type C standard are different from those which are stated in type A or B standards, the provisions of this type C standard take precedence over other standards, for machines that have been designed and built according to the provisions of this type C standard.

1 Scope

1.1 This European Standard deals with the technical requirements to minimise the risks due to the hazards listed in clause 4, which can arise during installation¹, operation and maintenance of permanently installed equipment and systems for the power driven parking of motor vehicles, as defined in 3.1 to 3.4 below. Requirements are also given on the provision of information for use, which includes requirements for the drafting of the instructions. Electromagnetic compatibility requirements are also covered.

1.2 This European Standard applies to equipment and systems for the power driven parking of motor vehicles which have four wheels, are within a maximum size envelope of 5,30 m long, by 2,30 m wide, by 2,20 m high and have a mass less than 2500 kg. The equipment can be manually or automatically controlled.

1.3 This standard does not cover:

- a) vehicle lifts (see EN 1493);
- b) peripheral devices, which do not handle motor vehicles, e.g. parking meters, ticket machines;
- c) requirements related to the building even if they support directly stored vehicles;
- d) goods only lifts in accordance with EN 81-31;
- e) power driven parking equipment intended for lifting and/or transporting any person;
- f) transmission and interface of remote controls;
- g) automatic parking equipment with transfer areas which move;
- h) the use of power driven parking equipment by wheelchair users and deaf persons;
- i) the workplace of any attendant.

1.4 This standard does not deal with the following:

- a) hazards arising if loads, or other items fall from vehicles;
- b) hazards arising if fuel or oil leaks from vehicles;
- c) hazards caused by operating the equipment/system in electromagnetic fields outside the range of EN 61000-6-2;
- d) hazards caused by operating the equipment/system in areas subject to special regulations (e.g. explosive atmospheres, fire risks);
- e) hazards caused by the use of dangerous/toxic materials, e.g. special hydraulic oil;
- f) hazards caused by noise;
- g) hazards arising from inadequate lighting of the surrounding of automatic parking systems and/or the place of installation of non-automatic parking equipment;
- h) hazards caused by earthquakes;
- i) hazards caused by vandalism;
- j) hazards due to the use of programmable electronic systems related to safety functions;

¹ When carried out by or on behalf of the purchaser

EN 14010:2003+A1:2009 (E)

- k) hazards due to the use of cableless control devices;
- l) hazards arising due to collision caused by the driver of the vehicle.

This document is not applicable to power driven parking equipment and systems manufactured before the date of publication of this document by CEN.

2 Normative references

^{A1} The following referenced documents are indispensable for the application of this document. For dated references, only the edition cited applies. For undated references, the latest edition of the referenced document (including any amendments) applies. ^{A1}

^{A1} *deleted text* ^{A1}

EN 294:1992, *Safety of machinery — Safety distance to prevent danger zones being reached by the upper limbs*

EN 349:1993, *Safety of machinery — Minimum gaps to avoid crushing of parts of the human body*

EN 418:1992, *Safety of machinery — Emergency stop equipment, functional aspects; principles for design*

EN 457, *Safety of machinery — Auditory danger signals — General requirements, design and testing (ISO 7731:1986, modified)*

EN 811, *Safety of machinery — Safety distances to prevent danger zones being reached by the lower limbs*

EN 842, *Safety of machinery — Visual danger signals — General requirements, design and testing*

EN 894-2, *Safety of machinery — Ergonomics requirements for the design of displays and control actuators — Part 2: Displays*

EN 953, *Safety of machinery — Guards — General requirements for the design and construction of fixed and movable guards*

EN 954-1:1996, *Safety of machinery — Safety-related parts of control systems — Part 1: General principles for design*

EN 982:1996, *Safety of machinery — Safety requirements for fluid power systems and their components — Hydraulics*

EN 1005-2, *Safety of machinery — Human physical performance — Part 2: Manual handling of machinery and component parts of machinery*

EN 1005-3, *Safety of machinery — Human physical performance — Part 3: Recommended force limits for machinery operation*

EN 1037:1995, *Safety of machinery — Prevention of unexpected start-up*

EN 1050:1996, *Safety of machinery — Principles for risk assessment*

^{A1} *deleted text* ^{A1}

EN 1088, *Safety of machinery — Interlocking devices associated with guards — Principles for design and selection*

EN 1760-2, *Safety of machinery — Pressure sensitive protective devices — Part 2: General principles for the design and testing of pressure sensitive edges and pressure sensitive bars*

EN 1837, *Safety of machinery — Integral lighting of machines*

- EN 12150-1, *Glass in building — Thermally toughened soda lime silicate safety glass — Part 1: Definition and description*
- EN 12385-4, *Steel wire ropes — Safety — Part 4: Stranded ropes for general lifting applications*
- EN 12385-5, *Steel wire ropes — Safety — Part 5: Stranded ropes for lifts*
- EN 12433-1, *Industrial, commercial and garage doors and gates — Terminology — Part 1: Types of doors*
- EN 12453, *Industrial commercial and garage doors and gates — Safety in use of power operated doors — Requirements*
- EN 12604, *Industrial, commercial and garage doors and gates — Mechanical aspects — Requirements*
- prEN 12624, *Industrial, commercial and garage doors and gates — Operational noise — Requirements and test methods*
- EN 12635, *Industrial, commercial and garage doors and gates — Installation and use*
- EN 12978, *Industrial, commercial and garage doors and gates — Safety devices for power operated doors and gates — Requirements and test methods*
- prEN 13241, *Industrial, commercial and garage doors and gates — Product standard*
- EN 13411-2, *Terminations for steel wire ropes — Safety — Part 2: Splicing of eyes for wire rope slings*
- prEN 13411-3, *Terminations for steel wire ropes — Safety — Part 3: Ferrules and ferrule-securing*
- prEN 13411-6, *Terminations for steel wire ropes — Safety — Part 6: Asymmetric wedge socket*
- EN 60204-1:1997, *Safety of machinery — Electrical equipment of machines — Part 1: General requirements (IEC 60204-1:1997)*
- EN 60529, *Degrees of protection provided by enclosures (IP Code) (IEC 60529:1989)*
- EN 60947-5-1:1997, *Low-voltage switchgear and controlgear — Part 5-1: Control circuit devices and switching elements — Electromechanical control circuit devices (IEC 60947-5-1:1997)*
- EN 61000-6-2, *Electromagnetic compatibility (EMC) — Part 6-2: Generic standards — Immunity for industrial environments (IEC 61000-6-2:1999, modified)*
- EN 61000-6-3, *Electromagnetic compatibility (EMC) — Part 6-3: Generic standards - Emission standard for residential, commercial and light-industrial environments (IEC 61000-6-3:1996, modified)*
- EN 61310-1, *Safety of machinery — Indication, marking and actuation — Part 1: Requirements for visual, auditory and tactile signals (IEC 61310-1:1995)*
- EN 61310-2, *Safety of machinery — Indication, marking and actuation — Part 2: Requirements for marking (IEC 61310-2:1995)*
- EN 61496-1, *Safety of machinery — Electro-sensitive protective equipment — Part 1: General requirements and tests (IEC 61496:1997)*
- A1** EN ISO 12100-1:2003, *Safety of machinery — Basic concepts, general principles for design — Part 1: Basic terminology, methodology (ISO 12100-1:2003)*
- EN ISO 12100-2:2003, *Safety of machinery — Basic concepts, general principles for design — Part 2: Technical principles (ISO 12100-2:2003)* **A1**
- EN ISO 12543-2, *Glass in building — Laminated glass and laminated safety glass — Part 2: Laminated safety glass (ISO 12543-2:1998)*

EN 14010:2003+A1:2009 (E)

EN ISO 14122-1, *Safety of machinery — Permanent means of access to machinery — Part 1: Choice of fixed means of access between two levels (ISO 14122-1:2001)*

EN ISO 14122-2, *Safety of machinery — Permanent means of access to machinery — Part 2: Working platforms and walkways (ISO 14122-2:2001)*

EN ISO 14122-3, *Safety of machinery — Permanent means of access to machinery — Part 3: Stairs, stepladders and guard-rails (ISO 14122-3:2001)*

prEN ISO 14122-4, *Safety of machinery — Permanent means of access to machinery — Part 4: Fixed ladders (ISO/FDIS 14122-4:2002)*

ISO 3864, *Graphical symbols — Safety colours and safety signs*

ISO 7000, *Graphical symbols for use on equipment — Index and synopsis*

ISO 13050:1999, *Curvilinear toothed synchronous belt drive systems*

IEC 61496-2, *Safety of machinery — Electro-sensitive protective equipment — Part 2: Particular requirements for equipment using active opto-electronic protective devices (AOPDs)*

3 Terms and definitions

[A1] For the purposes of this document, the terms and definitions given in EN ISO 12100-1:2003 and the following apply. **[A1]**

3.1

automatic parking system

automatic parking equipment together with its linked ancillary equipment, e.g. main door, working area door, side door, emergency door

3.2

automatic parking equipment

power driven parking equipment for motor vehicles, which stores and retrieves motor vehicles in an automatically sequenced mode (see 5.11 and annex B). The equipment, which may include structural elements, is permanently installed

3.3

non-automatic horizontally moving parking equipment

power driven parking equipment for motor vehicles, which has a load carrier which is moved in a non-automatically sequenced mode only in the horizontal plane. The horizontal movement is either under permanent control of the user or partially automatic. The equipment is permanently installed

3.4

non-automatic vertical parking equipment

power driven parking equipment for motor vehicles, which is moved vertically exclusively or with separate horizontal movement in a non-automatically sequenced mode and has only one defined fixed access point for the load carrier. Each movement is under permanent control of the user or partially automatic. The equipment is permanently installed

3.5

ancillary equipment

3.5.1

main door

door between the access area outside an automatic parking equipment and the parking equipment itself, which is used by motor vehicles and users and passengers, to enter and exit the transfer area (see annex B)

3.5.2

working area door

door between the transfer area and the working area (see annex B)

3.5.3

side door

pedestrian door which is intended to be used by users and passengers to give access to the transfer area (see annex B)

3.5.4

service door

pedestrian door which is intended to be used by trained personnel to give access to the working area (see annex B)

3.5.5

emergency door

pedestrian door which is intended to be used solely for persons leaving the respective area in emergencies, e.g. fire (see annex B)

3.5.6

pass door

part of a door leaf for pedestrians only (see EN 12433-1 and annex B)

3.6

other definitions

3.6.1

safety switch

control switch having one or more break-contact elements coupled to the switch actuator via non-resilient members so that full contact opening of the break contact element(s) is obtained when the actuator is moved through the positive opening travel by applying the force stated by the switch manufacturer

NOTE See annex K of EN 60947-5-1:1997.

3.6.2

rated load (carrying capacity)

maximum load per parking space that power driven parking equipment has been designed to carry

3.6.3

transfer area

area within automatic parking equipment in which vehicles are transferred to, or taken from, to reach the working area. The transfer area is intended to allow for at least the driver to leave or to enter the vehicle (see annex B)

3.6.4

working area

area in which the vehicle is handled. Within automatic parking equipment this area is not intended to be accessed by the user(s) (see annex B)

3.6.5

user

person who parks and/or retrieves a vehicle, using power driven parking equipment

3.6.6

type test

testing of a representative sample of a new design or of one which incorporates deviations from an existing design, which is conducted by or on behalf of the manufacturer or his authorised representative

3.6.7

load carrier

part of power driven parking equipment on which a single motor vehicle is located

3.6.8

transmission element

component through which force is transmitted from the power source to the load carrier. Transmission elements include e.g. gear boxes, hydraulic cylinders, lead screws and nuts, steel wire ropes, toothed belts and chains

3.6.9

lifting element

transmission element through which force is transmitted to raise or lower the load carrier

3.6.10

suspension element

vertical transmission elements consisting of ropes, toothed belts and chains

3.6.11

wheel track width

distance between the centre lines of the wheels on one axle

3.6.12

wheel base

distance between the centres of wheels on the front and rear axle

3.6.13

locking device

device which prevents the load carrier from leaving a defined position

3.6.14

safety gear

mechanical device which is designed to stop and to hold the load carrier if the load carrier is overspeeding

3.6.15

parking unit

one or several load carriers connected together mechanically and move at a whole

3.6.16

parking equipment attendant

person(s) given the task of operating and/or cleaning and/or supervising power driven parking equipment

3.6.17

public use

where the power driven parking equipment is intended to be used by untrained users

4 List of significant hazards

This clause contains all the significant hazards, hazardous situations and events, as far as they are dealt with in this standard, identified by risk assessment as significant for this type of equipment and which require action to eliminate or reduce the risk.

The list of significant hazards is based on EN 1050 and is using the numbering of annex A of EN 1050:1996. Also shown are the sub-clause references to the safety requirements and/or protective measures in the present standard.

Before using this standard it is important to carry out a risk assessment of the equipment to check that its significant hazards are identified in this clause.

Table 1 - List of hazards

No	Hazards	Relevant clauses of this standard
1	Mechanical hazards	
	Mechanical hazards due to machine parts or work pieces caused, for example, by:	
	— Relative location	5.8.4, 5.8.5
	— Mass and stability (potential energy of elements which may move under the effect of gravity)	5.6, 5.7.5
	— Mass and velocity (kinetic energy of elements in controlled or uncontrolled motion)	5.5.2, 5.7.5, 5.8.1, 5.8.8, 5.9.1, 5.9.2, 5.9.4, 5.11.1, 5.11.10
	— Inadequacy of mechanical strength	5.1.1, 5.5.3, 5.6, 5.11.10.2, annex 'A'
	Mechanical hazards due to accumulation of energy inside the machinery, caused for example, by:	
	— Liquids under pressure	5.4
1.1	Crushing hazard	5.2.3.1.1, 5.2.3.1.2, 5.2.3.1.4, 5.8.4, 5.8.5, 5.9.1, 5.9.3, 5.10.1, 5.11.3, 5.11.4, 5.11.5, 5.11.8, 5.11.10, 5.11.11, 5.11.12
1.2	Shearing hazard	5.7.6, 5.8.2, 5.11.3, 5.11.4, 5.11.5, 5.11.8, 5.11.10, 5.11.11, 5.11.12
1.3	Cutting or severing hazard	5.8.2, 5.11.3, 5.11.4, 5.11.5, 5.11.8, 5.11.10, 5.11.11, 5.11.12
1.4	Entanglement hazard	5.7.6, 5.11.3, 5.11.4, 5.11.5, 5.11.8, 5.11.10, 5.11.11, 5.11.12
1.5	Drawing-in or trapping hazard	5.2.3.6, 5.5.4, 5.7.6, 5.8.2, 5.8.3, 5.10.4, 5.10.6, 5.10.7, 5.11.3, 5.11.4, 5.11.5, 5.11.8, 5.11.10, 5.11.11, 5.11.12
1.6	Impact hazard	5.2.3.1.2, 5.8.1, 5.9.1, 5.11.3, 5.11.4, 5.11.5, 5.11.10, 5.11.11, 5.11.12
1.7	Stabbing or puncture hazard	5.11.10.1

continued

Table 1 (continued)

No	Hazards	Relevant clauses of this standard
1.9	High pressure fluid injection or ejection hazard	5.4
2	Electrical hazards due to:	
2.1	Contact of persons with live parts (direct contact)	5.3.1, 5.3.2, 5.3.3, 5.3.4
2.2	Contact of persons with parts which have become live under faulty conditions (indirect contact)	5.3.1, 5.3.3, 5.3.4
2.3	Access to live parts under high voltage	5.3.1, 5.3.2, 5.3.3, 5.3.4
2.4	Electrostatic phenomena	5.3.1, 5.3.5
3	Thermal hazards, resulting in:	
3.1	Burns and scalds and other injuries by a possible contact of persons with objects or materials with an extreme high or low temperature, by flames or explosions and also by the radiation of heat sources	Not Dealt With See 1.4d)
4	Hazards generated by noise, resulting in:	
4.1	Hearing loss (deafness), other physiological disorders (e.g. loss of balance, loss of awareness)	Not Dealt With See 1.3f) & 1.4f)
4.2	Interference with speech communication, acoustic signals, etc.	Not Dealt With See 1.3f) & 1.4f)

continued

Table 1 (continued)

No	Hazards	Relevant clauses of this standard
7	Hazards generated by materials and substances (and their constituent elements) processed or used by the machinery	
7.2	Fire or explosion hazard	Not Dealt With See 1.4d)
8	Hazards generated by neglecting ergonomic principles in machinery design as, e.g. hazards from:	
8.1	Unhealthy postures or excessive effort	Not Dealt With See Clause '1.3i)' & See Clause 'Introduction' - Negotiations
8.4	Inadequate local lighting	5.11.2, 7.1.2.2 & See Clause '1.4g)'
8.6	Human error, human behaviour	5.2.2, 5.2.3, 5.4.4, 5.8.8, 5.10.2, 5.10.5, 5.11.3, 5.11.4, 5.11.5, 5.11.7, 5.11.10, 5.11.11, 5.11.12, 5.11.13, 7.1.1, 7.1.3, 7.1.5, 7.2
8.7	Inadequate design, location or identification of manual controls	5.2.3, 5.11.13
8.8	Inadequate design or location of visual display units	5.2.3.1.2
9	Combinations of hazards	5.1.2

continued

Table 1 (continued)

No	Hazards	Relevant clauses of this standard
10	Unexpected start-up, unexpected overrun/ overspeed (or any similar malfunction) from:	
10.1	Failure/disorder of the control system	5.2.2, 5.2.4, 5.11.6, 5.11.14
10.2	Restoration of energy supply after an interruption	5.2.3.2, 5.2.4
10.3	External influences on electrical equipment	5.2.5.2
10.5	Errors in the software	Not Dealt With See Clause '1.4j'
10.6	Errors made by the operator (due to mismatch of machinery with human characteristics and abilities, see 8.6 above)	5.2.2, 5.2.3, 5.4.4, 5.8.8, 5.10.2, 5.10.5, 5.11.3, 5.11.4, 5.11.5, 5.11.6, 5.11.7, 5.11.10, 5.11.11, 5.11.12, 5.11.13, 5.11.14, 7.1.1, 7.1.3, 7.1.5
11	Impossibility of stopping the machine in the best possible conditions	5.2.3.3, 5.2.3.4, 5.11.7
13	Failure of the power supply	5.2.3.6, 5.2.4.1
14	Failure of the control circuit	5.2.2.1, 5.2.2.2, 5.2.2.3, 5.2.4, 5.11.6, 5.11.7, 5.11.14
15	Errors of fitting	5.3.4, 5.4.4, 7.1.1, 7.1.2.3, 7.1.4
16	Break-up during operation	5.1.1, 5.4.3.6, 5.4.3.7, 5.5.3, 5.6, 7.1.2.1, 7.1.3, 7.1.4, annex 'A'
17	Ejected fluids	5.4
18	Loss of stability/overtipping of machinery	5.5.2, 5.6.1.4, 7.1.1, 7.1.2.1, 7.1.2.3, 7.1.3
19	Slip, trip and fall of persons (related to machinery)	5.5.3, 5.5.6, 5.5.7, 5.6.1.8, 5.8.9, 5.10.8, 5.11.9

continued

Table 1 (concluded)

No	Hazards	Relevant clauses of this standard
27.1	Mechanical hazards and hazardous events, from load falls, collisions, machine tipping, caused by:	
27.1.1	Lack of stability	5.5.2, 5.6.1.4, 7.1.1, 7.1.2.1, 7.1.2.3, 7.1.3
27.1.2	Uncontrolled loading - overloading - overturning moments exceeded	Not Dealt With See Clause 'Introduction' - Assumptions
27.1.3	Uncontrolled amplitude of movements	5.4.3.6, 5.4.3.7, 5.10.1, 5.10.2
27.1.4	Unexpected/unintended movement of loads	5.5.5, 5.6.1.7, 5.6.1.8, 5.10.3
27.1.5	Inadequate holding devices/accessories	5.5.5, 5.6.1.7, 5.6.1.8
27.2	From access of persons to load support	5.6.1.8, 7.1.3.2
27.3	From derailment	5.5.2, 5.6.1.5, 5.6.2.6, 5.6.4.8, 5.6.5.3, 5.6.6.3
27.4	From insufficient mechanical strength of parts	5.1.1, 5.4.3.6, 5.4.3.7, 5.6, 5.11.10.2, 7.1.2.1, 7.1.4, annex 'A'
27.5	From inadequate design of pulleys, drums	5.6.2.4, 5.6.2.6, 5.6.4.6, 5.6.4.7, 5.6.5.1, 5.6.5.2, 5.6.5.3, 5.6.5.6, 5.6.5.7
27.6	From inadequate selection of chains, ropes, lifting and accessories and their inadequate integration into the machine	5.6
27.7	From lowering of the load under the control of friction brake	5.7.5
27.8	From abnormal conditions of assembly/testing/ use/ maintenance	5.2.3.7, 5.6.1.9, 5.6.4.9, 5.6.6.5, 5.11.8, 5.11.9, 7.1.4
27.9	From the effect of load on persons (impact by load or counterweight)	Not Applicable
28	Electrical hazard	
28.1	From lightning	5.2.5.2
29	Hazards generated by neglecting ergonomic principles	
29.1	Insufficient visibility from the driving position	5.2.3.1.2, 5.8.4

5 Safety and EMC requirements and/or safety measures

5.1 General

For the application of EN 294, EN 457, EN 842, EN 953, EN 954-1:1996, 5.3, prEN 1005-2, EN 1005-3, EN 1837, EN 60204-1 the manufacturer shall carry out an adequate risk assessment for the requirements thereof where choice is necessary.

NOTE This specific risk assessment is part of the general risk assessment relating to the hazards not covered by this "C" standard.

Power driven parking equipment and systems shall comply with the safety requirements and/or protective measures of this clause. In addition, power driven parking equipment and systems shall be designed according to the principles of A_1 EN ISO 12100 A_1 for hazards, which are relevant but not significant, which are not dealt with by this document (e.g. sharp edges).

5.1.1 Design criteria

The design shall be based on the criteria mentioned in annex A. Where less favourable situations occur the actual forces and their position shall be taken into account.

5.1.2 Combinations of hazard

Dealing with each separate hazard is considered to cover their combinations.

5.2 Control devices and equipment used for safety purposes

5.2.1 General

Control devices and equipment used for safety purposes, depending on the design, include all equipment and circuits associated with e.g.:

- ultimate tripping and position tripping functions;
- malfunction and fault detection functions;
- interlocking functions;
- overspeed tripping functions;
- braking functions;
- start functions;
- stop and emergency stop functions.

5.2.2 Devices and equipment

Control devices, safety devices, transmission elements, response elements, control systems used for safety purposes, shall be in accordance with the requirements of EN 954-1 Category 1 (see 6.2.2 in EN 954-1:1996), unless stated otherwise.

Where electronic equipment, or electronic devices including electronic sub-assemblies are used for safety purposes unless otherwise specified such electronic equipment and devices shall be in accordance with the requirements of EN 954-1 Category 2 (see 6.2.3 in EN 954-1:1996).

Electronic control circuitry, software, adjustable safety devices and adjustable safety related equipment shall be protected against access by unauthorised persons (e.g. by the use of access codes, special tools).

Control devices shall be located out of the passage gauge of the vehicles.

5.2.2.1 Safety device

Safety devices, e.g. trip devices, ultimate-position switches, slack lifting element switches, "door-locked" switches, interlocking switches, emergency stop devices, ultimate-position valves, overspeed governors, shall be located and installed to prevent them being damaged or rendered inoperative during any foreseeable operating conditions. They shall only be adjustable using tools and shall be accessible for inspection purposes from the working area. If a hazardous situation arises and a safety device is actuated, the appropriate safety device shall automatically initiate a category "0" or category "1" stop function as appropriate to be compatible with the design (see EN 60204-1:1997, 9.2.2) and prevent any movement in the relevant plane, unless stated otherwise. The stop function shall comply with EN 954-1, 5.2.

After release of an actuated safety device, it shall only be possible to initiate powered movement by a new start command.

5.2.2.1.1 Electrical safety devices

The switching arrangements of electrical safety devices, shall be of positive opening operation in accordance with Chapter 3 of EN 60947-5-1:1997 (i.e. "safety switches" as defined in 3.6.1 above).

With the exception, on automatic parking equipment, of ultimate switches on movements with a vertical component and those on horizontal movements without mechanical limiting devices other types of switching arrangement may be used, subject to the following conditions:

- i) mechanically actuated electrical switches which are not "safety type" switches, shall be duplicated, shall utilise break contacts and the switches shall be wired in series.
- ii) If sensing devices are used they shall be automatically monitored, which shall at least ensure that an error signal or faulty operation of the sensing device shall be detected prior to the start of the associated movement, i.e. shall meet the requirements of at least EN 61496-1 type 2.
- iii) If the monitoring system (see 5.11.14), shall detect an error signal, or unacceptable signal deviation, the monitoring system shall automatically initiate positive interruption of the associated powered movement and prevent further movement in that direction.

5.2.2.1.2 Hydraulic safety devices

Hydraulic safety devices shall be designed and installed to achieve a safety level comparable to the requirements for electrical safety devices specified above.

5.2.2.1.3 Mechanical safety devices

Mechanical safety devices shall be designed and installed to achieve a safety level comparable to the requirements for electrical safety devices specified above.

5.2.2.2 Transmission elements used for safety purposes

Transmission elements, e.g. safety related wiring, pipework, rods, safety ropes, chains, shall be designed so that failure shall not lead to a dangerous condition. In the event of failure or rupture, a category "0" or category "1" stop function shall be automatically initiated, as appropriate to be compatible with the design (see EN 60204-1:1997, 9.2.2). The stop function shall comply with EN 954-1:1996, 5.2. Mechanical components shall have factors of safety of at least 4 to 1 in relation to maximum intended loading, without permanent deformation or failure.

All flexible piping, flexible hoses and also any rigid pipework or connections used as transmission elements for safety purposes, shall be designed to withstand at least 4 x maximum working pressure without failure or permanent deformation.

The safety factor for the overspeed governor rope shall be at least 8 to 1, computed from the maximum force when the safety gear is initiated in relation to the minimum breaking load in accordance with the rope manufacturer's specifications.

Wiring/pipework used for safety purposes shall be installed and protected to prevent damage due to external influences.

5.2.2.3 Response elements used for safety purposes

Response elements include, e.g. safety related contactors, full-flow directional valves, locking devices, brakes, safety gear.

5.2.2.3.1 Full flow directional valves which are used for safety purposes shall be designed so that in the event of valve control pressure failure the valve shall not move to a dangerous position for the system.

This requirement may be fulfilled by either:

- a) a mechanically and positively actuated full flow directional valve which acts directly on the relevant part of the hydraulic system, or
- b) a pilot operated full flow directional valve controlled by a mechanically and positively actuated hydraulic safety device. The pilot operated full flow directional valve, shall in the event of control pressure failure, positively interrupt the associated movement and prevent further movement in that direction. The full flow directional valve shall also incorporate the following design features to ensure that it shall not be prevented from operating correctly in the event of a spring failure:
 - i) compression springs shall be guided to prevent them buckling and prevent the ends becoming displaced during use ; in combination with ii) or iii)
 - ii) compression springs shall have both ends guided ; or
 - iii) compression springs shall be selected such that the wire diameter is greater than the distance between the coils, hence preventing coils from winding into each other in the event of breakage.

5.2.2.3.2 Full flow solenoid directional valves shall not be used alone for safety purposes.

5.2.3 Control devices

5.2.3.1 General

The purpose/function of all control devices shall be clearly and indelibly marked by using symbols (see EN 894-2, ISO 3864 and ISO 7000), or the purpose/function shall be given in the languages of the country of use. Where intended for public use the purpose/function shall be given at least in the languages of the country of use. The way in which control devices are actuated and their relative position shall be logical and where practicable shall correspond to the resulting movement.

5.2.3.1.1 In the case of non-automatic parking equipment, control devices shall be of the hold-to-run type and shall be clearly and indelibly marked with the parking unit to which they belong.

5.2.3.1.2 "Hold-to-run" control devices on non-automatic parking equipment shall be located where the user or parking equipment attendant has an unrestricted view (direct or indirect view e.g. using viewing aids) of the area where the load carrier moves. All control devices and viewing aids shall be located on the control station.

5.2.3.1.3 In the case of non-automatic parking equipment, each parking unit shall be controlled separately.

5.2.3.1.4 For automatic parking equipment the control devices in general shall be out of reach of the users. Only the control devices needed for the use of the parking equipment shall be in reach of the user.

5.2.3.1.5 For all types of parking equipment, if powered operation of parking units can be initiated from several control stations, these shall be mutually interlocked, so that it is only possible to initiate movement from the selected control station.

5.2.3.1.6 Control device(s) shall not be accessible from inside the vehicle with the exception of devices for opening the main door of automatic parking equipment.

5.2.3.2 Start function

Start control devices shall be clearly identifiable and visible. They shall also be constructed, mounted and secured so as to minimise the risk of unintended or unauthorised operation as follows.

5.2.3.2.1 A start control device shall be provided for automatic parking equipment and shall be located outside the reach of users.

5.2.3.2.2 Actuating the hold-to-run control of non-automatic parking equipment may be considered as actuating the start function.

5.2.3.3 Stop function

The stop function shall be a category "0" or category "1" in accordance with EN 60204-1:1997, 9.2.2 as appropriate to be compatible to the design. When a stop control device has been actuated, powered motion shall cease. The parking equipment shall then remain in a stationary condition until the start control device has subsequently been actuated.

Stop control devices shall be provided at all control stations and shall be clearly identifiable and visible. Stop actuators shall have positive operation and shall have a projecting headed operator.

In the case of non-automatic parking equipment under the permanent control of the user a hold to run control device may be used for the stop function. Being in the released position shall actuate the stop function. When a "hold to run" control device is released, a category "0" or category "1" stop function shall be automatically initiated, as appropriate to be compatible with the design (see EN 60204-1:1997, 9.2.2) irrespective of the movement.

5.2.3.4 Emergency stop function

The emergency stop function shall be in accordance with EN 418 and shall be a category "0" stop (see EN 418:1992, 4.1.5).

NOTE The provision of an emergency stop device is not an alternative to the installation of suitable guarding, see EN 418:1992, 4.1.3.

5.2.3.4.1 When an emergency stop control device has been actuated, powered motion shall come to a halt. The parking equipment shall then remain in a stationary condition until the device has been reset and the start control device has subsequently been actuated.

5.2.3.4.2 In the case of non-automatic parking equipment; as an alternative to an emergency stop control at each control station, in accordance with EN 60204-1:1997, 10.7.5, a supply disconnecting device may be used if all the following preconditions are satisfied:

- it is readily accessible to the user, i.e. the distance from the supply disconnecting device to any related control station is not more than 20 m;
- it is positioned at a height between 1,6 m to 1,9 m;
- it is of the type described in EN 60204-1:1997, 5.3.2 a), b), or c);
- it meets the colour requirements of EN 60204-1:1997, 10.7.4.

5.2.3.4.3 For non-automatic parking equipment where it is not intended to move the equipment during maintenance or cleaning a lockable main switch outside the installation shall be provided (see 5.3.2). The switch mentioned in 5.2.3.4.2 may be used for this purpose.

5.2.3.4.4 Emergency stop control device(s) shall be provided for the protection of persons in the working area of automatic parking equipment. These shall be readily accessible and within reach of all accessible dangerous parts of the equipment including at walkways and transfer points.

5.2.3.4.5 For automatic parking equipment which can be divided into discrete sections e. g. main door, transfer area, vertical lift, horizontal movement, separate emergency stop devices shall be provided for each discrete section.

The emergency stop control device in the transfer area shall be protected against misuse, e.g. positioned behind glass and requiring the breakage of the glass before it can be actuated.

In addition, for attendant controlled equipment, an emergency stop control device shall be provided at the attendant control station.

For cleaning purposes an emergency stop is not required. A lockable isolation device (see 5.3.2) shall be provided.

For maintenance or cleaning of automatic parking equipment where it is intended to move the equipment, a means shall be provided, e.g. plug-in remote control(s) with cable lengths allowing emergency stop to be operated anywhere within the parking equipment.

5.2.3.4.6 In the case of automatic parking equipment, stop control devices shall be provided in the transfer area(s) and the working area and shall be clearly identifiable and visible. Stop actuators shall have positive operation and shall be self-latching.

Unless the stop control device is designed to be positioned behind glass (see 5.2.3.4.5 above), the stop actuator shall normally have a projecting mushroom shaped or palm shaped push button.

5.2.3.5 The restarting means after an emergency stop of automatic parking equipment shall be out of reach of the users.

5.2.3.6 Emergency exit control device

In the case of automatic parking equipment, there shall be a means of exiting from the transfer area in an emergency also in the case of loss of main power. If an emergency door or pass door is not provided, to enable the main door to be opened, a suitable "door open" control device or a manual means to open the main door shall be provided in the transfer area. If an emergency door is opened or a "door open" control device is actuated, the control signal allowing motion in the transfer area shall be removed.

In the situation restart of the equipment shall be out of the reach of the user.

Restarting shall remain under control of all safety devices.

5.2.3.7 Emergency entrance control device

In the case of automatic parking equipment, there shall be a means of entering the transfer area in an emergency. To enable an entry door to be opened, a suitable "door open" control device shall be provided which shall be secured against unauthorised operation. In this type of situation a control signal shall be sent to stop and prevent motion in the transfer area.

In the situation restart of the equipment shall be out of the reach of the user.

Restarting shall remain under control of all safety devices.

5.2.4 Control systems

5.2.4.1 Electrical and electronic control systems

The control system shall be designed and constructed in accordance with all applicable clauses of EN 60204-1, using proven techniques and using proven components (see 9.4 of EN 60204-1:1997). In the event of supply interruption and restoration of supply (see 7.5 in EN 60204-1:1997), excessive supply fluctuation, or a fault or a failure of the control system, a hazardous situation shall not occur (e.g. failure to stop, unexpected start-up) (see 4.2 of EN 954-1:1996). When the power supply is switched-on there shall be no movements of the machinery. Integrated circuits may be used in supervised safety circuits and/or in monitoring systems if the malfunction of one integrated circuit does not lead to a hazardous situation.

5.2.4.2 Hydraulic control systems

The control system shall be designed and constructed using proven techniques and shall use proven components (see EN 982). The safety related parts of the control system shall be designed in accordance with the requirements of EN 954-1 Category 1 (see 6.2.2 in EN 954-1:1996). When the power supply is switched-on there shall be no movements of the machinery. In the event of supply interruption and restoration of supply, excessive supply fluctuation, or a fault or a failure of the control system, a hazardous situation shall not occur (e.g. failure to stop, unexpected start-up) (see 4.2 in EN 954-1:1996 and 5.1.4 in EN 982:1996).

5.2.5 Electromagnetic compatibility (EMC)

5.2.5.1 EMC (General aspects)

The electromagnetic disturbances generated by the power driven parking equipment shall not exceed the levels specified in generic emission standard EN 61000-6-3. The power driven parking equipment shall also have sufficient immunity to electromagnetic disturbances to enable it to operate as intended when exposed to the levels and types of disturbance as specified in EN 61000-6-2. The manufacturer of the power driven parking equipment shall design, install and wire the equipment and sub-assemblies, taking into account the recommendations of the supplier(s) of the sub-assemblies, to ensure that the effects of electromagnetic disturbances thereon shall not lead to unintended operation.

In particular, the following loss of performance or degradation of performance shall not occur:

- any sequencing, timing or counting errors affecting the function
- speed variation in excess of $\pm 20\%$
- increase/decrease of starting operation duration by more than 10 %
- reduction in non-safety related fault detection capability

For those tests specified in EN 61000-6-2, any degradations of performance or loss of function allowed with regard to performance criteria "A" & "B" shall be declared by the manufacturer. Any temporary loss of function allowed with regard to performance criteria "C" shall be declared by the manufacturer.

NOTE Information on measures to reduce generated disturbances and measures to reduce the effects of disturbances on the power driven parking equipment is given in EN 60204-1:1997, 4.4.2.

5.2.5.2 EMC (Safety related aspects)

The power driven parking equipment shall also have sufficient immunity to electromagnetic disturbances to enable it to operate safely as intended and shall not fail to danger, when exposed to the levels and types of disturbance as specified in EN 61000-6-2.

The manufacturer of the power driven parking equipment shall design, install and wire the equipment and sub-assemblies, taking into account the recommendations of the supplier(s) of the sub-assemblies, to ensure that the effects of electromagnetic disturbances thereon shall not lead to unsafe operation and/or failure to danger.

EN 14010:2003+A1:2009 (E)

The following performance criteria shall be used to determine the result (pass / fail) of EMC immunity testing:

- a) For those tests specified in EN 61000-6-2, the performance criteria as specified in EN 61000-6-2 shall apply.
- b) With regard to all of the performance criteria specified in EN 61000-6-2 (A, B etc.), there shall be no loss of performance or degradation of performance which could lead to danger. In particular, the following losses of performance or degradations of performance, shall not occur:
 - unexpected start-up (see EN 1037)
 - blocking of an emergency stop command, or resetting of the emergency stop function (see EN 418 and EN 60204-1)
 - inhibition of the operation of any safety related circuit as in 5.2.1 (see EN 1088)
 - any reduction in safety-related fault detection capability.

NOTE Information on measures to reduce the effects of electromagnetic disturbances on the power driven parking equipment is given in EN 60204-1:1997, 4.4.2.

5.3 Electrical equipment

5.3.1 General

The electrical equipment of power driven parking equipment shall be provided in accordance with all applicable clauses of EN 60204-1, together with the particular requirements below. Clauses from EN 60204-1 which have particular relevance for power driven parking equipment, are also mentioned in the clauses below.

NOTE Electrical equipment includes materials, fittings, devices, appliances, fixtures, apparatus and the like, used as part of, or in connection with, the electrical installation of the power driven parking equipment. This includes electronic equipment, the means of disconnection from the supply and all wiring on and from the power driven parking equipment to the means of disconnection from the supply.

5.3.2 Means of disconnection

Provision shall be made to prevent unexpected start-up and electric shock when work is being carried out on power driven parking equipment or its electrical equipment (see EN 1037 and EN 60204-1:1997, 5.4 and 5.5). A disconnecting device shall be provided which satisfies the requirements of either EN 60204-1:1997, 5.3.2 a), 5.3.2 b) or 5.3.2 c). In the case of automatic parking equipment the disconnecting device shall only be accessible to authorised persons, for non-automatic parking equipment, see 5.2.3.4.2 above. The disconnecting device shall be marked with purpose and type of operation and shall be capable of being locked in the "isolated" position or capable of being secured in another manner in accordance with EN 1037:1995, 5.2. If the power driven parking equipment is part of a system which is sub-divided into individual sections, each section having a discrete supply, each individual section shall be capable of disconnection from the supply to allow work to be carried out. Where parts remain live after switching off the disconnecting device (e.g. due to inter-connections between sections of a system) such parts shall be marked/ identified/ protected as appropriate (see 5.2.3.4.3 and EN 60204-1:1997, 5.3.5 and 6.2).

5.3.3 Environment

The supplier shall select and install equipment which is suitable for the intended working environment. Enclosures for the electrical equipment (including control device enclosures) shall provide suitable protection, e.g. they shall have a minimum degree of protection of IP 4X, where enclosures are accessible to all persons they shall have a minimum degree of protection of IP 44 and when outdoors they all have a minimum degree of protection of IP 65 (see EN 60529). If parking equipment is for use in special conditions, outside the scope of EN 60204-1, e.g. ambient air temperature, humidity, altitude, the manufacturer shall make any necessary design modifications, take any necessary safety precautions and/or state any operational restrictions in the operating manual.

5.3.4 Wiring practices

Wiring practices used on power driven parking equipment and from power driven parking equipment to the means of disconnection from the supply, including any work carried out on site, shall meet the requirements of EN 60204-1:1997, clause 14. This includes identification techniques and wiring methods used both inside and outside enclosures. Where practicable, wiring external to enclosures shall not be located in proximity to combustible material (motor vehicles are not considered as combustible materials) or located where it may be subject to mechanical damage. Where this is unavoidable, wiring shall be suitably protected, e.g. in rigid conduit, electrical flexible tubing, raceway or other suitable means. Electrical equipment shall be designed, marked and arranged, as far as is practicable to prevent or deter the making of incorrect connections which could result in a risk of injury (e.g. reversal of the direction of movement or influencing the function of a safety device).

5.3.5 Electrostatic charges

Hazards including shock and explosion may be caused by electrostatic charges. If it has been identified that persons may be directly or indirectly endangered by such charges, suitable protective measures shall be taken (e.g. earth bonding, brush contact or discharge element for moving items, see CLC Report No. R044-001).

5.4 Hydraulic systems and hydraulic equipment

5.4.1 General

Hydraulic systems and hydraulic equipment used for power driven parking equipment shall be provided in accordance with all applicable clauses of EN 982, together with the particular requirements below. Clauses from EN 982 which have particular relevance for power driven parking equipment are also given below.

NOTE Hydraulic equipment on power driven parking equipment includes materials, fittings, devices, appliances, fixtures, apparatus and the like, used as part of, or in connection with, the hydraulic installation of the power driven parking equipment. This includes hydraulic fluid reservoirs, hydraulic fluid pumps, valves, cylinders, hydraulic motors, accumulators and all piping. Hydraulic systems consist of several components of hydraulic equipment.

5.4.2 Hydraulic systems

5.4.2.1 Hydraulic systems shall be designed and constructed to prevent or minimise surges in working pressure, e.g. use of accumulators.

5.4.2.2 Hydraulic systems shall be provided with a means to provide protection against over-pressure, which shall be tamper-resistant if accessible to all persons including children, e.g. shall only be adjustable using tools, or lockable (see EN 982:1996, 5.3.5.1). Over-pressure protection shall act at a pressure not exceeding 1,4 x maximum working pressure. The preferred means of over-pressure protection is a pressure relief valve, which shall be fitted adjacent to the pump delivery (see EN 982:1996, 5.1.2).

5.4.2.3 Hydraulic systems shall have a means of disconnection, to prevent unexpected start-up which could cause injury when maintenance work or adjustments are being carried out on the hydraulic equipment. This provision shall be either electrical disconnection of the pump-drive motor or hydraulic disconnection by means of a valve or a plug/socket coupling, as appropriate. The disconnecting device shall be readily accessible to authorised personnel, shall be marked with purpose and type of operation and shall be capable of being locked in the "disconnected" position or capable of being secured in another manner (see EN 1037:1995, 5.2 and EN 982:1996, 5.1.6).

If the equipment is part of a system which is sub-divided into individual sections, each individual section shall be capable of disconnection from the supply to allow work to be carried out.

Where parts of a system remain pressurised after disconnection (e.g. due to inter-connections, or due to the use of hydraulic accumulators in that part of the circuit) each individual pressure source shall be capable of disconnection to allow work to be carried out safely. Such parts of the system shall be appropriately marked/identified/ protected (see EN 982:1996, 5.3.4.5.1).

5.4.2.4 Hydraulic systems which incorporate hydraulic accumulators shall meet the requirements of EN 982:1996, 5.3.4.5.

5.4.2.5 Hydraulic systems shall be provided with suitable means of checking the working pressure at appropriate points in the system, e.g. the provision of suitable quick action coupling points. These coupling points shall be protected against unauthorised use if pressurised, e.g. lockable.

5.4.2.6 Hydraulic systems shall incorporate appropriate devices, immediately before each safety related locking valve, and suitable procedures shall be used to ensure that the cleanliness of the hydraulic fluid is suitable for the particular system (see EN 982:1996, 5.3.4.1.3 and 5.3.7).

5.4.2.7 Hydraulic systems shall be able to withstand a static pressure of at least 20 % above the normal setting of the over-pressure protection. e.g. 1,6 times the maximum working pressure.

5.4.3 Hydraulic equipment

5.4.3.1 General

The supplier shall select and install equipment which shall be suitable for the intended working environment. If equipment is intended to operate in abnormal conditions, which may adversely affect the operation of the equipment, e.g. ambient air temperature, humidity, altitude, the manufacturer shall make any necessary design modifications, take any necessary safety precautions and/or state any operational restrictions in the operating manual. Enclosures for the hydraulic equipment (including control device enclosures) shall provide suitable protection. All equipment e.g. pumps, motors, flexible piping, shall be compatible with the hydraulic fluid used (see EN 982:1996, 5.3.4.1)

5.4.3.2 Fluid reservoirs shall meet the requirements of EN 982:1996, 5.3.4.4.

5.4.3.3 With the exception of 5.4.3.6 and 5.4.3.7 hydraulic equipment, e.g. actuators, accumulators, valves, pipework and their connections, shall be designed to withstand at least 3 x maximum working pressure without failure or permanent deformation.

5.4.3.4 Gas loaded accumulators providing hydraulic fluid for safety related functions shall comply with EN 982:1996, 5.3.4.5 and shall incorporate a minimum fluid level detection device. If the minimum fluid level is reached, the device shall automatically give a stop command.

5.4.3.5 Cylinders used as lifting elements, shall have a suitable valve, which shall be either directly connected or integral, to prevent lowering of the load carrier in the event of pipe or hose failure. This valve need not be fixed directly to the cylinder if between the valve and cylinder only rigid steel pipe with "security swaged" fittings or similar connections are used (see Figure 1 and Figure 2 below).

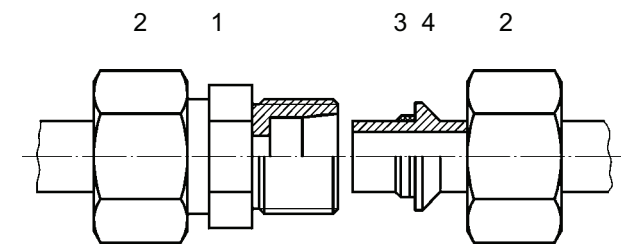

Key

- 1 Fitting body
- 2 Nut
- 3 Captive seal
- 4 Security swaged pipe

Figure 1 — Security swaged fitting type 1

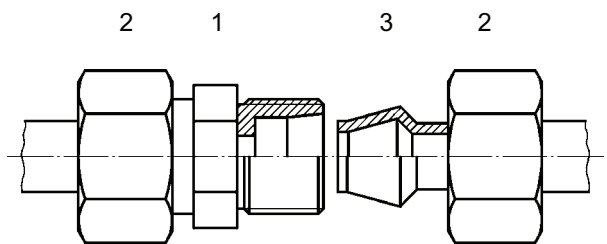

Key

- 1 Fitting body
- 2 Nut
- 3 Security swaged pipe

Figure 2 — Security swaged fitting type 2

5.4.3.6 In the case of direct acting hydraulic cylinders, if the end of the cylinder is used to stop movement and the cylinder is provided with cushioning, the cylinder shall be able to withstand a static force equivalent to twice the maximum working pressure without failure or permanent deformation.

Cylinder stops without cushioning shall be able to withstand a static force equivalent to at least 3 times the maximum working pressure without failure or permanent deformation. If safety related, they shall be able to withstand a static force equivalent to at least 4 times the maximum working pressure without failure or permanent deformation.

5.4.3.7 In the case of direct acting hydraulic cylinders, when fully extended the cylinder shall be able to withstand a static force equivalent to twice the maximum working pressure without buckling, failure or permanent deformation.

5.4.4 Piping practices

Piping practices used on power driven parking equipment, including any work carried out on site, shall meet the requirements of EN 982:1996, 5.3.4.2 and 5.3.4.3. System design, identification techniques and work on site, shall where practicable prevent or deter incorrect connection or reconnection which could result in risk of injury (e.g. reversal of a direction of movement or adversely affecting a safety function). Piping shall be suitably installed to discourage the entrapment of air, as any entrained air in the hydraulic fluid will affect the compressibility of the fluid and may lead to a hazardous situation. Where practicable, non-metal and/or flexible piping shall not be installed where it may be subject to mechanical damage, e.g. sharp bends, torsion, chafing, contact with moving parts or installed in proximity to combustible material. Where this is unavoidable, such piping shall be protected.

5.5 Load carrier

5.5.1 Load carriers shall be designed so that persons can enter and alight parked vehicles at the access position or in the transfer area of automatic parking systems.

5.5.2 Load carriers shall be designed to receive vehicles and carry them. Where load carriers are moved vertically by non-guided supports means shall be provided at the loading positions to take over the horizontal forces due to loading.

Means shall be provided to reduce the risk of horizontally moving load carriers leaving the guides.

5.5.3 If a user or passenger could fall more than 1 m from the load carrier surface, it shall have protection provision at least 1 m high. Where a railing is used, a handrail, knee-height rail and a kick plate at least 0,05 m high shall be provided. Protection provision is not required where locally the distance between the load carrier and stationary or moving parts in the environment is less than 0,2 m. The handrail shall be designed to withstand a side load of 300 N at any position along its length, without deflecting more than 0,1 m.

The safety distance from handrails and knee-height rails to adjacent moving parts shall be at least 0,08 m.

5.5.4 On automatic systems the horizontal clearance between the load carrier and the area accessible to the user surrounding the load carrier shall be a maximum of 0,04 m.

On non-automatic vertical parking equipment the clearance between the load carrier and the access point to the user at the entrance of the load carrier shall be maximum of 0,04 m.

5.5.5 Load carriers shall have devices (e.g. wheel stops, wheel troughs, positioning aids), which enable the vehicle to be parked so that the safe operation of the power driven parking equipment is ensured.

5.5.6 In areas intended to be accessed by the user, the load carrier shall have a continuous surface and openings shall be avoided. Where openings are necessary, e.g. for water evacuation, they shall not allow a ball of more than 30 mm of diameter to pass through and the surface of the load carrier shall be anti-slip, e.g. ridged.

5.5.7 In areas intended to be accessed by the user, the transfer area shall have a continuous surface and openings shall be avoided. Where openings are necessary, e.g. for water evacuation, they shall not allow a ball of more than 30 mm of diameter to pass through.

5.6 Lifting elements

5.6.1 General

5.6.1.1 Lifting elements shall be suspension elements, hydraulic cylinders, leadscrews/nuts or rack/pinion. Pneumatic cylinders shall not be used.

5.6.1.2 Suspension elements shall be at least two, and be mutually independent.

5.6.1.3 Suspension elements shall be provided with means to approximately equalise their tensioning. This may include differential movement of toothed-wheels/sprockets. This requirement may be regarded as fulfilled if e.g. the lifting element(s) are attached to opposite sides of the load carrier.

NOTE This requirement can be regarded as fulfilled if the flexibility of the components is appropriate.

Spring loaded tensioning elements shall be used where only two suspension elements are used.

5.6.1.4 Where eccentric loading can unload suspension elements, provisions shall be made to compensate this.

5.6.1.5 Means shall be provided to prevent suspension elements or other flexible lifting elements from leaving the pulley groove, chain wheel, sprocket wheel and driving elements.

5.6.1.6 Parking equipment with suspension elements shall be provided with slack lifting element safety device(s). This also applies to the overspeed governor chain or rope.

5.6.1.7 An automatic device shall be provided to avoid unintended lowering of the load carrier. This condition shall be regarded as satisfied by either:

- a) locking device (see 3.6.13) where toothed belt, chain, indirect hydraulic or steel rope lifting elements are used;
- b) valve according to 5.4.3.5 for hydraulic lifting elements; lowering due to internal leakage shall never exceed 30 mm within 24 h.

5.6.1.8 If failure of lifting elements may cause persons to fall more than 1 m, e.g. when entering or leaving a vehicle, suitable safety equipment shall be provided, e.g. safety gear actuated by an overspeed governor, a hydraulic valve in accordance with 5.4.3.5 or a safety nut in accordance with 5.6.6.2. In the event of failure, this safety equipment shall either hold the load carrier plus rated load, or gradually bring it to a stop. The average deceleration shall not exceed $1,0g_n$. If the safety gear is actuated, or the safety nut becomes loaded, such malfunction shall be detected in accordance with 5.11.14.

5.6.1.9 Lifting elements shall be designed to be accessible for servicing and inspection purposes.

5.6.2 Steel wire rope used as lifting elements

5.6.2.1 Steel wire ropes shall be in accordance with EN 12385-4 or EN 12385-5 depending on the drive type and shall consist of at least 114 individual wires. They shall not have more than one fibre core.

5.6.2.2 The tensile strength of the individual wires in a steel wire rope for lifting elements shall be at least 1570 N/mm² and shall not exceed 1960 N/mm².

The minimum breaking load for steel wire ropes shall be at least five times the maximum possible static load with the rated load in the most unfavourable position.

The minimum breaking load of the steel wire ropes shall be proved by a certificate.

5.6.2.3 The nominal diameter of steel wire ropes shall be at least 7 mm. The nominal diameter of overspeed governor ropes shall not be less than 6 mm.

5.6.2.4 Rope pulleys and rope drums shall have a diameter of least 18 times the rope diameter if single sheave and a diameter of least 22 times the rope diameter when reeved. The pulley and drum diameters relate to the centre of the rope.

5.6.2.5 Only the following means shall be used to secure ropes:

- spliced eyes (see EN 13411-2);
- ferrule secured eyes - aluminium turned back loops - flemish eyes (see prEN 13411-3);
- asymmetric wedge socket clevises (see prEN 13411-6).

The connection between wire rope and wire rope fixing (end connection) shall be capable of transmitting at least 80% of the minimum breaking load of the wire rope, which shall be proved by a certificate.

5.6.2.6 All rope drums shall be grooved and provided with means to prevent the rope from leaving the drum. They shall have a minimum of two dead turns of rope on the drum with the load carrier in its lowest position. Only one layer of rope is permitted unless a spooling system is used which correctly places the rope.

Traction sheaves shall not be used.

5.6.3 Chains used as lifting elements

5.6.3.1 In the case of chains the minimum breaking load shall be at least four times the maximum possible static load with the rated load in the most unfavourable position.

5.6.3.2 The minimum breaking load of the chain shall be proven by a certificate.

5.6.3.3 The connection between chains and chain fixing (end connection) shall be capable of transmitting at least 80% of the breaking load required to provide a safety factor of 4.

5.6.4 Toothed belts used as lifting elements

5.6.4.1 Toothed belts shall be protected from direct contact with water, oil, lubricants and solvents.

5.6.4.2 Toothed belts used as lifting elements shall be generally in accordance with ISO 13050 and shall be made of rubber with brass-coated steel wire tensile-members. In applications where high humidity combined with heat may be encountered, then the tensile-members shall be brass-coated stainless steel.

5.6.4.3 The minimum breaking load for a toothed belt used as a lifting element shall be at least five times the maximum static load which could occur in each toothed belt, with the rated load in the most unfavourable position.

5.6.4.4 Connections between the drum/load carrier, structure and the belt shall be capable of transmitting at least 80 % of the breaking load required to ensure a safety factor of 5.

5.6.4.5 The end opposite to the suspension elements (main load) shall be tensioned in accordance with the toothed belt manufacturer's recommendations. Means shall be provided to keep the toothed belt on the drive pulley.

5.6.4.6 Drive pulleys shall be made from hard wearing material, e.g. steel, cast iron, hard anodised aluminium, shall have machine cut teeth, shall be flanged, shall not be less than the minimum diameter according to the manufacturer's recommendation and shall be in accordance with the tolerances in ISO 13050:1999, Tables 7, 17 and 25 and shall engage the minimum amount of teeth as recommended by the belt manufacturer.

5.6.4.7 Idler pulleys in contact with the toothed belt surface shall have machine cut teeth, shall be flanged and shall not be less than the outside diameter of the smallest toothed pulley in the system. Idler pulleys in contact with the back of the toothed belt shall have a smooth uncrowned periphery.

5.6.4.8 The fleet angle between pulley and toothed belt shall not exceed 0,25°.

5.6.4.9 Toothed belt transmission or lifting elements shall be designed to enable them to be visually inspected, without removing them or without extensive dismantling of stress bearing parts of the equipment.

5.6.5 Rack and pinion lifting elements

5.6.5.1 When rack and pinion lifting elements are used the overspeed governor shall be driven by a separate safety device pinion.

5.6.5.2 The safety device pinion shall be machine-cut from steel and shall be arranged beneath the driving pinions.

5.6.5.3 In addition to the normal load carrier guide rollers, positive and effective means shall be provided which is designed to prevent any driving or safety device pinion from coming out of engagement with the rack. This means shall be designed to ensure that axial movement of the pinion(s) is so limited that a minimum of 2/3 of the tooth width is always in engagement with the rack. This means shall also be designed to restrain radial movement of the pinion(s) from its normal meshing position by more than 1/3 of the tooth depth. This requirement also applies in the event of failure of a counter-pulley or another arrangement which is designed to secure engagement or in the event of local bending or distortion of a supporting structure to which the toothed rack is secured.

5.6.5.4 Racks and pinion lifting elements shall be machine-cut from steel and the minimum tooth-pitch shall be module 7. A factor of safety of at least 6 against the ultimate tensile strength of the material shall be provided, based on the total suspended static load. For the purpose of this calculation all the forces shall be considered to act on one tooth only.

5.6.5.5 Toothed racks shall be tightly secured to the supporting structure, particularly at their ends. Toothed rack elements shall be accurately positioned at joints, e.g. within 0,01 tooth pitch in order to ensure accurate meshing of the pinions.

5.6.5.6 If several driving pinions engage with the toothed rack, a self-adjusting device shall be provided which is designed to share the load between all drive pinions.

5.6.5.7 Pinions shall not be used to guide the load carrier.

5.6.5.8 It shall be possible to visually inspect the pinions without removing them or without extensive dismantling of stress-bearing parts of the parking equipment.

5.6.6 Leadscrew/nut lifting elements

5.6.6.1 Leadscrews and nuts shall be designed so that the minimum breaking load shall be at least six times the rated load in the most unfavourable position. The leadscrew arrangement shall be designed to prevent separation of the load carrier from the leadscrew during normal use. Means shall be provided to avoid buckling of the screw or disconnection of the nut towards the suspension element if this one is blocked due to external reasons.

5.6.6.2 Each leadscrew shall have a load bearing nut and an unloaded safety nut. The safety nut shall only be loaded if the load bearing nut fails. It shall not be possible for the load carrier to be raised under power if the safety nut becomes loaded. A safety switch or other safety devices shall be provided which prevents upward travel under these pre-conditions.

5.6.6.3 Leadscrew systems shall have devices (e.g. mechanical end stops) at both ends to prevent the load bearing and/or safety nuts from leaving the leadscrew.

5.6.6.4 The design life of leadscrews shall be greater than that of the load bearing nuts (i.e. the leadscrew material shall have a higher abrasion resistance than the load bearing nut material). The lifetime of the joints in the leadscrew shall also be considered.

5.6.6.5 It shall be possible to detect the wear of the load bearing nuts without major disassembly.

5.6.6.6 Drives with recirculating ball screws and nuts shall only be used if they are designed to provide a level of safety equivalent to 5.6.6.1 to 5.6.6.5.

5.6.7 Hydraulic lifting elements (see 5.4)**5.7 Transmission elements**

5.7.1 Pneumatic equipment shall not be used as transmission elements.

5.7.2 Transmission elements shall be designed to be accessible for servicing and inspection purposes.

5.7.3 Horizontally moving load carriers may be equipped with a means for manually driven operation. Such means if fitted shall meet the following requirements:

- a) it shall be readily accessible and shall be designed such that the person carrying out the manual operation will not put at risk;
- b) the direction of movement of the load carrier shall be clearly and indelibly marked.

5.7.4 Wire rope, chain, toothed belt, leadscrew/nut or rack/pinion transmission elements shall be equipped with a means which operates automatically and which is capable of slowing down the load carrier from the rated speed with the test load.

5.7.5 Brakes shall be designed to meet the following requirements:

- a) the force for applying the brakes shall be produced by guided compression type springs which shall have:
 - i) both ends of the springs guided to prevent them buckling and prevent the ends becoming displaced during use; or
 - ii) the springs shall be selected such that the wire diameter is greater than the distance between the coils, hence preventing coils from winding into each other in the event of breakage.
- b) brakes shall be applied automatically if the power supply is interrupted in any way;
- c) if brakes can be released by hand they shall be automatically activated when released.

5.7.6 Transmission elements (e.g. gearwheels, chains, shafts, wheels) shall either be safeguarded in accordance with Table 2, 3, 4 or 6 of EN 294:1992, or safeguarded using fixed guards to reduce the risk of injury (see EN 953).

5.8 Non-automatic horizontally moving parking equipment in areas accessible to the user

5.8.1 Load carriers for horizontally moving equipment shall move at a maximum speed of 0,2 m/s.

5.8.2 Load carrier edges which are parallel to the direction of movement shall have no recesses on their edges so that the risk of cutting or shearing is minimised.

The clearance between moving parts of load carriers which are not parallel to the direction of movement (e.g. edges, approach ramps, wheel troughs, covers) and the floor shall not exceed 0,02 m in order to avoid the risk of drawing in of lower limbs between load carrier leading edges and the floor (see EN 811 and Figure C.1).

The clearance between moving parts of load carriers which are parallel to the direction of movement and the floor shall not exceed 0,02 m in order to avoid the risk of drawing in of lower limbs between load carrier leading edges and the floor (see EN 811 and annexes Ca and Cb). Where this is not possible the minimum distance between the outer edge and the wheel(s) shall be at least 0,05 m.

5.8.3 Load carriers which move horizontally and in the direction of the vehicle axis i.e. longitudinally, shall have load carrying surfaces which are not more than 0,10 m above the floor (see EN 811 and Figure C.2). All edges of load carriers which move longitudinally shall be designed in such a way that a motor vehicle can drive on and/or over the load carrier.

5.8.4 To safeguard against persons being crushed, load carriers and vehicles parked on them in accordance with the operating instructions shall have distances between them and adjacent load carriers, other parked vehicles or fixed parts in the environment in accordance with the following:

5.8.4.1 Load carriers that are moved at 90° to the vehicle axis.

The following safety distances (see Figure C.1) are required for load carriers which have unrestricted visibility across the operating area from the control station:

- 0,12 m minimum between the outer edges of two load carriers normal to the direction of movement, with the exception of buffers and coupling devices;
- 0,40 m minimum between the inside of the edges of two adjacent load carriers;
- 0,18 m minimum between the outer edges of the load carrier normal to the direction of movement and fixed parts in the environment;
- 0,32 m minimum between the inside of the edges of the load carrier normal to the direction of movement and fixed parts in the environment;
- 0,30 m between the bumpers of a parked vehicle and fixed parts in the environment or the bumpers of other vehicles.

If visibility is restricted, safety devices shall be provided in accordance with 5.9.

More than one row of load carriers or installations of parking equipment more than 30 m long or excessive obstructions, e.g. columns in the line of view, are regarded as causing restricted visibility.

5.8.4.2 Load carriers that are moved in the direction of the vehicle axis

The following safety distances (see Figure C.2) are required for load carriers which have unrestricted visibility across the operating area from the control station:

- 0,12 m minimum between the outer edges of two load carriers normal to the direction of movement;
- 0,18 m minimum in the direction of movement from the outer edges of the load carrier to fixed parts in the environment with the load carrier in the final position;
- 0,12 m minimum between load carrier outer edges parallel to the direction of movement and fixed parts in the environment;
- 0,40 m minimum between the inside edges of the load carrier and fixed parts in the environment;
- 0,30 m between the bumpers of a parked vehicle and fixed parts in the environment or the bumpers of other vehicles.

If visibility is restricted, safety devices shall be provided in accordance with 5.9.

Parking equipment with more than one row of load carriers, or excessive obstructions, e.g. columns in the line of view, are regarded as causing restricted visibility.

This is also the case for single-row load carriers

- more than 20 m in the direction of travel or 10 m in the opposite direction in the case of a control station which is accessible from the vehicle;
- more than 30 m in the direction of travel or 10 m in the opposite direction.

5.8.5 If load carriers are operated in groups, the requirements of 5.8.4 above are unnecessary. In particular, for this type of operation the control station shall be approximately 10 m away from the leading edges of the load carriers to be driven in groups.

5.8.6 Parking equipment which is moved in the direction of the vehicle axis in accordance with 5.8.4.2 shall be operated using hold-to-run control devices (see 5.2.3).

5.8.7 Parking equipment which is moved in the direction 90° to the vehicle axis where safety devices are fitted in accordance with 5.8.4.1 (see also 5.9.2), hold-to-run control is not required.

5.8.8 Access to the use of parking equipment shall be restricted to authorised persons e.g. by access code, magnetic card, key operated switch.

5.8.9 Where the load carrier is intended to remain out of the working area in the rest position (see introduction - negotiations) care shall be taken to avoid falling and tripping possibilities.

5.9 Safety devices for non-automatic horizontally moving parking equipment

5.9.1 General

If the safety distances stated in 5.8.4.1 and 5.8.4.2 cannot be observed due to the building design or if the parking equipment has restricted visibility from the control station, danger zones between moving parts or moving and stationary parts shall be safeguarded between 0,3 m and 1,5 m above the floor using safety devices, e.g. sensitive edges, light barriers, laser scanners. This does not apply to buffers and coupling devices.

The safety devices may be fitted to load carriers or other fixed parts in the environment.

Where damage to the safety devices can occur due to the presence of buffers and/or coupling devices the safety devices may be interrupted in the respective zones.

5.9.2 When the safety device is tripped the load carrier shall stop before injury to persons.

5.9.3 Danger zones at fixed parts at the end of the travel of the load carrier shall be safeguarded by e.g. active opto-electronic protective devices (see IEC 61496-2) installed horizontally at a height between 0,5 m and 0,7 m above the floor.

5.9.4 The movement of load carriers shall be indicated by flashing warning light(s) (see EN 61310-1 and EN 842) installed in prominent place(s).

5.10 Non-automatic vertically moving parking equipment in areas accessible to the user

5.10.1 A mechanical locking device (for hydraulic lifting elements see 5.4.3.5) shall be provided if, due to unintended lowering:

- a) there is a risk of crushing of persons or vehicles located beneath the load carrier when operated by the user;
- b) a collision between the load carrier and elements or parts of the building is possible in the case of tilting load carriers (see introduction-negotiations).

5.10.2 Vertical movements other than by indirect or direct acting hydraulic equipment travelling to the end of the cylinder shall be limited at the upper and lower working position by end limit devices and also ultimate limit switches in accordance with 5.2.2.1. If the ultimate limit switch is actuated due to failure of the end limit device, any subsequent movement away from the ultimate limit switch shall only be possible by or under the control of an authorised person. This does not apply to the lower end position when the load carrier is lowered under gravity.

5.10.3 If power driven parking equipment is designed to carry the load using several lifting elements, it shall be ensured that unintentional de-synchronisation of the lifting elements is limited within the following constraints:

- a) a difference in height of 50 mm,

or

b) a maximum of one degree tilt, measured between two random corners of a load carrier.

5.10.4 Parking equipment shall be operated at a lifting and lowering speed of maximum 0,15 m/s measured at the approach edge at the access point to the parking unit.

5.10.5 Access to the use of parking equipment shall be restricted to authorised persons e.g. by access code, magnetic card, key operated switch.

5.10.6 At the access point to the load carrier an optical warning means such as marking on the floor (see ISO 3864), flushing indicator light, shall be provided.

5.10.7 Vertical movements of the motor vehicle, load carrier, parking unit shall remain within the working area.

5.10.8 Where the load carrier is intended to remain out of the working area in the rest position (see introduction - negotiations) care shall be taken to avoid falling and tripping possibilities.

5.11 Automatic parking equipment

5.11.1 The system shall be designed such that if damage to the system or errors can occur due to simultaneous movements, these movements shall be interlocked.

5.11.2 A full illumination of the transfer area shall be ensured before accessing it. This full illumination shall remain effective at least 60 sec after detection of the absence of persons inside the transfer area.

5.11.3 Means shall be provided to prevent unauthorised persons from entering the transfer and the working areas of the parking equipment.

5.11.4 Service doors shall be constructed in such a way that they can only be opened from the outside with a key by authorised persons. It shall be possible to open them from the inside without a key. Service doors shall not open inwards into the working area and shall be self closing.

5.11.5 If a service door to the working area is opened the parking equipment shall be automatically stopped by a safety switch or other equivalent device (see 5.2.2.1.1). In such circumstances, restarting of the equipment shall only be possible when the service door is closed and in addition shall only be possible by or under the control of one authorised person, e.g. by using a retained key or equivalent reset system.

5.11.6 To prevent risks due to change from manual to automatic control, or vice versa, one or more key operated mode switches, or alternative means providing the same level of safety, shall be provided for the automatic parking equipment.

The mode switch shall be at a control position outside the working area

At the access to the working area a means shall be provided to ensure priority of the controls inside the working area towards any control outside.

5.11.7 The transfer area of an automatic parking system shall be equipped with (a) main door(s) and a means to exit the transfer area in an emergency and may be equipped with (a) side door(s).

5.11.8 Fixed enclosing guards, fixed distance guards or interlocking guards shall be provided to protect persons from crushing, shearing, entanglement, drawing-in and trapping hazards (see EN 953). ^[A1] When it is foreseen (e.g. maintenance) that the fixed guard will be removed regularly then the fastenings shall remain attached to the guard or to the machinery. ^[A1] Appropriate safety distances shall be in accordance with Table 1 of EN 349:1993 or Table 2, 3, 4 or 6 of EN 294:1992. Where this is not practicable, trip devices in accordance with EN 1760-2 or EN 61496-1 shall be provided to stop dangerous movement.

All lubrication and adjustment points used more frequently than monthly shall be accessible without it being necessary to remove any guards.

5.11.9 Walkways, control stations and platforms

Safe means of access complying with EN ISO 14122 parts 1, 2, 3 and prEN ISO 14122-4 shall be provided for access during installation. Permanent means of access complying with EN ISO 14122 parts 1, 2, 3 and prEN ISO 14122-4 shall be provided for access to control stations, working areas and places where maintenance, inspection, cleaning and lubrication are intended to be carried out more frequently than monthly. Where less the walkways may be reduced to the following:

- a) falling height up to 1 m:
 - width at least 0,30 m;
 - toeplate at least 0,10 m;
 - handrail 1,0 m high at one side.

- b) falling height more than 1 m:
 - width at least 0,30 m;
 - toeplate at least 0,10 m;
 - facilities for use of personal protective equipment against falling.

5.11.10 Doors for automatic parking equipment

Doors and safety devices shall be provided in accordance with prEN 13241, EN 12453, EN 12604, prEN 12624, EN 12978 and EN 12635, with the following additional requirements.

The suitability of doors defined in EN 12433-1 shall be in accordance with Table 2.

Table 2 — Suitability of various types of door for different applications

Type of door	Main door	Working area door	Side door	Service door	Emergency door	Pass door
Single leaf hinged door	NS	NS	x	x	x	x
Double leaf hinged door	NS	NS	NS	x	NS	NS
Single leaf swing door	NS	NS	NS	NS	NS	NS
Double leaf swing door	NS	NS	NS	NS	NS	NS
Sliding swing door	NS	NS	x	x	x	NS
Two leaf folded hinged door	x	NS	NS	NS	NS	NS
Triple leaf folded hinged door	x	NS	NS	NS	NS	NS
Folding door	x	x	NS	NS	NS	NS
Sliding folding door	x	x	NS	NS	NS	NS
Single leaf sliding door	x	x	x	NS	NS	NS
Bi-parting sliding door	x	x	x	NS	NS	NS
Multi-passing sliding door	x	x	NS	NS	NS	NS
Round the corner sliding door	x	x	NS	NS	NS	NS
Collapsible lattice	NS	NS	NS	NS	NS	NS
Vertical sliding door	x	x	NS	NS	NS	NS
Sectional overhead door	x	x	NS	NS	NS	NS
Roller blind door	x	x	NS	NS	NS	NS
Roller door	x	x	NS	NS	NS	NS
Up-and-over door	x	x	NS	NS	NS	NS
Barriers	NS	NS	NS	NS	NS	NS
NOTE x denotes 'suitable'; NS means 'not suitable';						

5.11.10.1 In working area doors only, open cut-outs shall be acceptable if designed in accordance with EN 294:1992, Tables 3 and 4, where there is a risk of injury. Cut-outs in other doors shall be filled with laminated safety glass or equivalent material (see EN 12150-1 and EN ISO 12543-2).

In the case of horizontally sliding powered doors, cut-outs in the doors are only permitted above a height of 1,1 m.

5.11.10.2 In the closed position doors shall have a mechanical resistance such that an evenly distributed force of 300 N on one or other side of the doors at any point perpendicular to the door surface and acting on a round or square area of 5 cm² neither distorts the door permanently nor impairs its normal operation.

5.11.10.3 Doors specified to be used by persons shall have an overall height of at least 2 m. This does not apply to doors designed to be used exclusively by trained personnel. In this case trap doors with minimum clearance dimensions in accordance with EN 547-1 and EN 547-3 may be used. i.e. min. width of 650 mm and min. height of 1000 mm.

5.11.10.4 Where main door(s) are intended to be operated by the user, only hold-to-run control devices shall be used. These control devices shall be arranged so that the hazardous area can be viewed from the operating position.

5.11.10.5 Any main and working area door shall be in accordance with EN 12453 and EN 12978.

5.11.10.6 It shall not be possible to open a door to the transfer area - or one of the door leaves where the door has several leaves - if the load carrier in the transfer area is not at rest (for emergency opening of the door see 5.2.3.6 and 5.2.3.7).

5.11.10.7 If a door to the transfer area or a door leaf in the case of doors with several leaves is not fully closed and secured this shall be detected automatically by suitable means, e.g. by positive link or redundant positive link, and motion of the load carrier shall be prevented (see 5.2.2.1).

5.11.10.8 Securing means shall not be accessible to the users.

5.11.10.9 If the securing means is in the form of a lock (see Figure 3 below as an example), it shall only be possible to move the load carrier if the locking device(s) has engaged by at least 7 mm. The lock shall withstand a force of 1000 N acting at the height of the lock in the direction of the movement of the door without either permanent distortion or releasing of the lock. The lock shall be engaged and permanently retained. Retaining means such as electromagnets, pneumatic and hydraulic devices shall not be used.

If compression springs are used they shall

- a) be guided to prevent them buckling and prevent the ends becoming displaced during use, and
- b) have both ends fixed; or
- c) be selected such that the wire diameter is greater than the distance between the coils, hence preventing coils from winding into each other in the event of breakage;
- d) their action shall not be impeded by pollution e.g. dust and ice.

There shall be no unlocking by gravity in the event of failure of the permanent magnet or of the springs.

If the locking device is held in the locked position by a permanent magnet, its effectiveness shall not be capable of being diminished by simple devices. Visual inspection of the working parts shall be possible, where appropriate by means of a transparent cover.

If locking detection switches are accommodated in housings, the screws for the housing cover shall remain captive in the housing or cover holes if the covers are opened.

The connection between the locking detection switch and the locking device shall be positive and where practicable shall not be adjustable. The door shall be closed and locked before detection is possible.

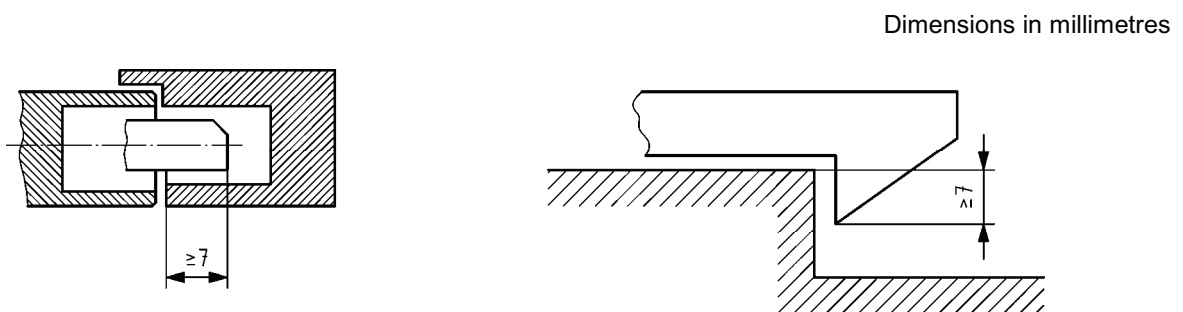

Figure 3 — Example of door securing device

5.11.10.10 These requirements of 5.11.10.8 are also satisfied if a force of more than 1000 N is required to open the door.

5.11.10.11 If a horizontally or vertically moving door has several door leaves that are linked to one another mechanically with at least 3 linkings it is permissible

- to secure only one door leaf if as a result of securing this door leaf the other door leaves cannot be opened;
- to have the detection means required in 5.11.10.7, for the closing position on a single door leaf.

5.11.11 Public use

In accordance with the increased risk when parking equipment is in public use, additional means shall be provided to reduce the risk of unauthorised persons being carried into the working area of the parking equipment i.e. additional checking shall be required {e.g. visual, CCTV by a parking equipment attendant see 5.11.12.3a (public use)}.

5.11.12 Operation of automatic parking equipment

5.11.12.1 General

Automatic parking equipment use shall always be sequenced as follows:

- the user deposits the vehicle in the transfer area;
- the vehicle is stored automatically;
- the vehicle is retrieved automatically;
- the user re-enters the vehicle and drives out of the transfer area.

5.11.12.2 Deposit of vehicle in the transfer area

5.11.12.2.1 For non public user(s) this shall be as follows:

a) Open of main door

Signal from outside using e.g. remote control, magnetic card, inductive loop, manual control device. The main door shall only open if all the other doors of the transfer area and if applicable the vertical recess are closed and secured.

b) Entry of vehicle

Drive vehicle in, vehicle shall be positioned in accordance with instructions, e.g. visual, audio. Vehicle to be secured in accordance with the instructions of the manufacturer of the parking equipment and/or of the vehicle.

c) Check of vehicle dimensions

using automatic means, e.g. active opto-electronic devices, laser scanners; which check whether or not the vehicle is located within the geometric limits (e.g. position, are doors open, height, extensions, superstructure). Alternative measures shall be used in the case of projecting parts which are difficult to detect (e.g. aerials).

d) Close of main door

i) manually operated

Persons exit the vehicle and leave the transfer area by the main door. The user shall verify that no person is in the transfer area. The main door is closed by the user by using e.g. magnetic card, manual control device.

ii) automatically operated

When main door is closed automatically, the side door(s) shall be unlocked. Persons exit the vehicle and leave the transfer area by the side door. Means shall be provided to initiate locking of the side door(s), e.g. magnetic card, manual control device.

NOTE Side door should be closed automatically by door closer.

5.11.12.2 For public user(s) this shall be as follows:

a. Open of main door

Signal from outside using inductive loop, manual control device, magnetic card, credit card, transponder chip. The main door shall only open if all the other doors of the transfer area and if applicable the vertical recess are closed and secured.

b. Entry of vehicle

Drive vehicle in, vehicle shall be positioned in accordance with instructions, e.g. visual, audio. Vehicle to be secured in accordance with the instructions of the manufacturer of the parking equipment and/or of the vehicle.

c. Check of vehicle dimensions

Using automatic means, e.g. active opto-electronic devices, laser scanners, which check whether or not the vehicle is located within the geometric limits (e.g. position, are doors open, height, extensions, superstructure). Alternative measures shall be used in the case of projecting parts which are difficult to detect (e.g. aerials).

d. Close of main door

If main door is closed automatically after entry of vehicle into the transfer area, the side door(s) shall be unlocked. Persons exit the vehicle and leave the transfer area by the side door, means shall be provided to initiate locking of the side door(s), e.g. magnetic card, credit card, transponder chip.

If persons are intended to leave the transfer area by the main door, means shall be provided to initiate closing of the main door, e.g. magnetic card, credit card, transponder chip.

NOTE Side door should be closed automatically by door closer.

5.11.12.3 Storage of vehicle

This shall be as follows:

a) Verify no person inside the transfer area

(non-public use)

- i) automatically, using e.g. laser scanner, active opto-electronic devices, or
- ii) manually following instructions, e.g. visual, audio.

(public use)

- i) automatically, using e.g. laser scanner, active opto-electronic devices, and
- ii) additional checking (e.g. by parking equipment attendant, using visual, CCTV)

b) **Locking of the main door and side door(s)**

When automatic verification has been completed satisfactorily then the door(s) shall be closed and secured automatically.

c) **Automatic operation**

EN 14010:2003+A1:2009 (E)

When main door and side door are closed and secured and all other doors are secured against access to the transfer area from the outside, then the working area door and/or vertical recess may be opened and the automatic storage of the vehicle may start.

NOTE It should only be possible to start the automatic operation if the vehicle dimension check has been completed satisfactorily.

5.11.12.4 Retrieval of vehicle

This shall be as follows:

a) Call for retrieval of vehicle

Signal from outside using e.g. remote control, magnetic card, manual control device.

b) Transfer of vehicle within the working area

If the working area door or main door or recess is secured, transfer may take place within the working area.

c) Closing of the main door if it is open

Before closing the main door, it shall be verified automatically, using e.g. laser scanner, active opto-electronic devices that no persons are present in the transfer area, then the door may close automatically.

d) Transfer of vehicle from the working area to the transfer area

Transfer of the vehicle shall only take place when the transfer area is secured against access from the outside and no persons are present in the transfer area.

5.11.12.5 Removal of vehicle by user

This shall be as follows:

a) Call for retrieval of vehicle

Signal from outside using e.g. remote control, magnetic card, credit card, transponder chip, manual control device(s).

b) Entry into transfer area by the user

Before allowing access into the transfer area the working area door and/or the vertical recess shall be closed and secured and the main door and/or side door shall release and/or open automatically.

c) Exit of vehicle

If the main door is not opened automatically, it may be opened using e.g. access control device, manual control device. The user can enter the vehicle and depart the transfer area by the main door.

5.11.12.6 Verify no person is inside the transfer area, then close and secure the main door and/or side door after the vehicle has departed (see also 5.11.12.3a)

- i) if automatic verification using e. g. laser scanner, active opto-electronic devices, then the door(s) may close and secure automatically, or
- ii) if manual verification, following instructions, e. g. visual, audio, then the door(s) shall only close and secure following operation of a manual control device.
- iii) if a person enters the transfer area whilst the main door is closing, the main door shall re-open. Re-closing of the main door shall only be possible after verifying again.

5.11.13 Sequence controls

5.11.13.1 In the case of automatic parking equipment, the control devices for opening the main door shall be positioned outside the transfer and working areas.

NOTE The transfer area and the door area should be monitored by the control device.

5.11.13.2 When a vehicle has been positioned inside the transfer area, initiation by the user of its automatic storage shall only be possible from outside the working and the transfer area.

NOTE The start control for closing the door and for automatic storage of the vehicle can only be accepted by the access medium that initiated the previous process.

5.11.13.3 The start control device for automatic retrieval of vehicles shall be located outside the working area and outside the transfer area.

5.11.13.4 In the case of automatic parking equipment where storage or retrieval of vehicles can be initiated from several control stations, these shall be mutually interlocked, so that it is possible to initiate operation from only one control station at the time. Operations shall be co-ordinated by the use of interlocks which shall ensure that movements are safely sequenced.

5.11.14 Safety device check

Automatic parking equipment shall, depending on the design, have one or more of the following automatic malfunction detection devices installed, which shall be constructed and mounted so as to minimise the risk of inadvertent operation:

- a) safety gear/safety nut switches (see 5.6.1.8);
- b) slack lifting element switches (see 5.6.1.6);
- c) ultimate-position switches (see 5.10.2);
- d) trip devices (see 5.11.8);
- e) load carrier locked switches (see 5.10.7);
- f) door locked switches (5.11.5);
- g) height and/or width sensing devices (see 5.11.12.2.1c and 5.11.12.2.2c);
- h) heat/movement sensing devices (see 5.11.12.3a).

If any fault or hazardous condition is detected, an unambiguous acoustic and/or visual warning, in accordance with EN 457, EN 842, EN 61310-1 as appropriate, shall be provided to the user or parking equipment attendant. Where appropriate, linked equipment shall be automatically slowed-down, or stopped in a controlled manner. Where there is risk of injury a stop shall be automatically initiated. In the situation restart of the equipment shall be out of the reach of the user. Restarting shall remain under control of all safety devices.

5.12 Design of the transfer area

The design of the transfer area shall prevent persons from climbing up to a height of 2 m without any assisting devices.

6 Verification of safety and EMC requirements and/or measures

6.1 Safety requirements and/or measures of clauses 5 and 7 of this standard shall be verified by the manufacturer according to the table below, which covers:

Type verification, i.e. verification of the machine type, the intention of which being to establish that the type of machine complies with the requirements of this standard (The first section of the table).

Individual verification, i. e. verification of each machine put on the market, the intention of which being to establish that before despatch, each machine satisfies all the safety requirements of this standard (The second section of the table). Where the machine is assembled on site, the part of the verification that cannot be made before despatch shall be carried out at the place of use.

The following methods of verification are included in Table 3:

- a) certificate check: the intention of which only being to establish whether the certificate relating to a component or equipment is adequate to meet the requirements of the standard (symbol "C" in the table);
- b) design check: the intention of which only being to establish whether the design of the machine, system or component is adequate to meet the requirements of the standard (symbol "D" in the table);
- c) visual check: the intention of which only being to establish, whether something is present on the machine, system or component (e.g. guarding, visual warning device, marking), or that documents, drawings provided for the user are adequate to meet the requirements of the standard (symbol "V" in the table);
- d) measurement: the intention of which being to establish whether the stated measurable parameters have been met (e. g. geometric dimensions, safety distances, isolation resistance of electric circuits) (symbol "M" in the table);
- e) functional test: the intention of which being to establish whether, in an unloaded working operation, normal cycle or part of cycle, the machine, including all safety devices, works as intended and all functions comply with the requirements of this standard (symbol "FT" in the table);
- f) loaded test(s): tests outside the range of functional tests, the intention of which being to establish whether, e.g. operation of all safety devices and their adjustments are adequate and the result of their actuation is in accordance with the requirements of this standard (symbol "LT" in the table);
- g) specific verification/ measurements (e.g. Electrical, EMC, the intention of which being to establish whether stated parameters have been met (e.g. compliance with electrical standards) (symbol "SV" in the table).

Table 3 — Verification of the requirements of this standard

Clauses of this standard	TYPE VERIFICATIONS			INDIVIDUAL VERIFICATIONS		
	Checks	Measurement	Tests	Checks	Measurement	Tests
5.1	D			D		
5.1.1	D			D		
5.2.1	D			D		
5.2.2	D, V		FT	V		FT
5.2.2.1	D, V		FT	D, V		FT
5.2.2.1.1	D, V		FT	D, V		FT
5.2.2.1.2	D, V		FT	D, V		FT
5.2.2.1.3	D, V		FT	D, V		FT
5.2.2.2	D, V		FT	V		FT
5.2.2.3	D, V		FT	V		FT
5.2.2.3.1	D, V		FT	V		FT
5.2.2.3.2	D, V		FT	V		FT
5.2.3.1	V		FT	V		FT
5.2.3.1.1	V		FT	V		FT
5.2.3.1.2	V		FT	V		FT
5.2.3.1.3	V		FT	V		FT
5.2.3.1.4	V		FT	V		FT
5.2.3.1.5	V		FT	V		FT
5.2.3.1.6	V		FT	V		FT
5.2.3.2	V		FT	V		FT
5.2.3.2.1	V		FT	V		FT
5.2.3.2.2	V		FT	V		FT
5.2.3.3	D, V		FT	V		FT
5.2.3.4	D, V		FT	V		FT
5.2.3.4.1	V		FT	V		FT
5.2.3.4.2	V		FT	V		FT
5.2.3.4.3	V		FT	V		FT
5.2.3.4.4	V		FT	V		FT
5.2.3.4.5	V		FT	V		FT
5.2.3.4.6	V		FT	V		FT
5.2.3.5			FT			FT
5.2.3.6	V		FT	V		FT
5.2.3.7	V		FT	V		FT
5.2.4.1	D, V		FT, SV _(6.2.3)	V		FT, SV _(6.2.3)
5.2.4.2	D, V		FT	V		FT
5.2.5						
5.2.5.1			SV _(6.2.1)			
5.2.5.2			SV _(6.2.2)			

continued

Table 3 (continued)

Clauses of this standard	TYPE VERIFICATIONS			INDIVIDUAL VERIFICATIONS		
	Checks	Measurement	Tests	Checks	Measurement	Tests
5.3.1	D, V		FT, SV _(6.2.3)	D, V		FT, SV _(6.2.3)
5.3.2	D, V		FT, SV _(6.2.3)	V		FT, SV _(6.2.3)
5.3.3	D, V		FT, SV _(6.2.3)	V		FT, SV _(6.2.3)
5.3.4	D, V		FT, SV _(6.2.3)	V		FT, SV _(6.2.3)
5.3.5	D, V			V		
5.4.1	D, V	M	FT	V	M	FT
5.4.2.1	D	M	FT		M	FT
5.4.2.2	D, V	M	FT	V	M	FT
5.4.2.3	D, V		FT	V		FT
5.4.2.4	D, V			V		
5.4.2.5	V			V		
5.4.2.6	D, V			V		
5.4.2.7	D		FT			FT
5.4.3.1	D, V			V		
5.4.3.2	D					
5.4.3.3	D, V	M	FT	V	M	FT
5.4.3.4	D, V		FT	V		FT
5.4.3.5	D, V		FT	V		FT
5.4.3.6	D, V			V		
5.4.3.7	V			V		
5.4.4	D, V			V		
5.5.1	D		FT			FT
5.5.2	V		FT	V		FT
5.5.3	D, V	M	FT	V	M	FT
5.5.4		M			M	
5.5.5	V			V		
5.5.6	D, V	M		V	M	
5.5.7	V	M		V	M	
5.6.1.1	D, V			V		
5.6.1.2	D, V			V		
5.6.1.3	D, V			V		
5.6.1.4	D, V			V		
5.6.1.5	V			V		
5.6.1.6	D, V			V		
5.6.1.7	D, V	M	LT	D, V	M	LT
5.6.1.8	D, V	M	FT	D, V	M	FT

continued

Table 3 (continued)

Clauses of this standard	TYPE VERIFICATIONS			INDIVIDUAL VERIFICATIONS		
	Checks	Measurement	Tests	Checks	Measurement	Tests
5.6.1.9	D, V			V		
5.6.2.1	D, V			V		
5.6.2.2	C, D			C, D		
5.6.2.3		M			M	
5.6.2.4	D	M		D	M	
5.6.2.5	D, V			D, V		
5.6.2.6	D, V		FT	V		FT
5.6.3.1	D, V			D, V		
5.6.3.2	C			C		
5.6.3.3	D, V			D, V		
5.6.4.1	D, V			D, V		
5.6.4.2	D, V			D, V		
5.6.4.3	C, D			C, D		
5.6.4.4	D, V			D, V		
5.6.4.5	D, V			D, V		
5.6.4.6	D, V	M		D, V	M	
5.6.4.7	D, V	M		D, V	M	
5.6.4.8	V	M		V	M	
5.6.4.9	D, V			V		
5.6.5.1	V			V		
5.6.5.2	V			V		
5.6.5.3	D, V			V		
5.6.5.4	C, D, V			C, V		
5.6.5.5	D, V	M		V	M	
5.6.5.6	D, V			V		
5.6.5.7	V			V		
5.6.5.8	V			V		
5.6.6.1	C, D, V		FT	C, D, V		FT
5.6.6.2	V		FT	V		FT
5.6.6.3	V		FT	V		FT
5.6.6.4	D, V			D, V		
5.6.6.5	V			V		
5.6.6.6	D			D		
5.7.1	V			V		
5.7.2	D, V		FT	V		FT
5.7.3	D, V			V		
5.7.4	V		LT	V		LT
5.7.5	D, V			V		

continued

Table 3 (continued)

Clauses of this standard	TYPE VERIFICATIONS			INDIVIDUAL VERIFICATIONS		
	Checks	Measurement	Tests	Checks	Measurement	Tests
5.7.6	V	M		V	M	
5.8.1	V	M		V	M	
5.8.2		M	FT		M	FT
5.8.3	D	M		D	M	
5.8.4.1	V	M	FT	V	M	FT
5.8.4.2	V	M	FT	V	M	FT
5.8.5	V	M	FT	V	M	FT
5.8.6	V		FT	V		FT
5.8.7	V		FT	V		FT
5.8.8	V			V		
5.8.9		M			M	
5.9.1	V	M	FT	V	M	FT
5.9.2	D, V	M	FT	V	M	FT
5.9.3	V	M	FT	V	M	FT
5.9.4	V		FT	V		FT
5.10.1	D, V		FT	V		FT
5.10.2			FT			FT
5.10.3		M	FT	M		FT
5.10.4		M	FT		M	FT
5.10.5	V		FT	V		FT
5.10.6	V		FT	V		FT
5.10.7	V		FT	V		FT
5.10.8	V		FT	V		FT
5.11.1	D		FT	D		FT
5.11.2	D		FT	D		FT
5.11.3	V		FT	V		FT
5.11.4			FT			FT
5.11.5	V		FT	V		FT
5.11.6	V		FT	V		FT
5.11.7	V			V		
5.11.8	D, V	M	FT	D, V	M	FT
5.11.9	D, V	M	FT	D, V	M	FT
5.11.10	D, V			D, V		
5.11.10.1	D, V	M		V	M	
5.11.10.2		M	FT		M	

continued

Table 3 (concluded)

Clauses of this standard	TYPE VERIFICATIONS			INDIVIDUAL VERIFICATIONS		
	Checks	Measurement	Tests	Checks	Measurement	Tests
5.11.10.3		M			M	
5.11.10.4	V		FT	V		FT
5.11.10.5	D, V			D, V		
5.11.10.6			FT			FT
5.11.10.7			FT			FT
5.11.10.8	V			V		
5.11.10.9	D, V	M	FT	D, V	M	FT
5.11.10.10	V	M	FT	V	M	FT
5.11.10.11	D, V		FT	D, V		FT
5.11.11	V		FT	V		FT
5.11.12.2						FT
5.11.12.3			FT			FT
5.11.12.4			FT			FT
5.11.12.5			FT			FT
5.11.12.6			FT			FT
5.11.13.1	V		FT	V		FT
5.11.13.2	V		FT	V		FT
5.11.13.3	V		FT	V		FT
5.11.13.4	D, V		FT	D, V		FT
5.11.14	D, V		FT	D, V		FT
5.12	D, V	M	FT	D, V	M	FT
7.1.1	V			V		
7.1.2	V			V		
7.1.3	V			V		
7.1.4	V			V		
7.1.5	V			V		
7.2.1	V			V		
7.2.2	V			V		

6.2 Special verification

6.2.1 EMC Compliance criteria (general aspects)

Compliance with the EMC requirements of 5.2.5.1 above shall be checked in accordance with the standards mentioned. If testing of the completed power driven parking equipment is not reasonably practicable due to the size of the machinery, the manufacturer shall verify that all appropriate equipment sub-assemblies comply with requirements of 5.2.5.1 above. The manufacturer shall also verify that these sub-assemblies are suitably installed and wired, to minimise the effects of disturbances on the equipment, to minimise generated disturbances and in accordance with any recommendations of the supplier(s) of the sub-assemblies.

6.2.2 EMC Compliance criteria (safety related aspects)

Compliance with the EMC requirements of 5.2.5.2 above shall be checked by carrying out preliminary testing and function testing. If testing of the completed power driven parking equipment is not reasonably practicable due to the size of the machinery, the manufacturer shall verify that all appropriate equipment sub-assemblies comply with requirements of 5.2.5.2 above. The manufacturer shall also verify, that these sub-assemblies are suitably installed and wired to minimise the effects of disturbances on the equipment and in accordance with any recommendations of the supplier(s) of the sub-assemblies.

6.2.3 Electrical equipment

Compliance with the requirements of 5.2.4.1, 5.3.1, 5.3.2, 5.3.3 and 5.3.4 above shall be checked in accordance with the standards mentioned. If testing of the completed power driven parking equipment is not reasonably practicable due to the size of the machinery, the manufacturer shall verify that all appropriate equipment sub-assemblies etc, comply with requirements of 5.2.4.1, 5.3.1, 5.3.2, 5.3.3 and 5.3.4 above.

6.3 Type testing

Power driven parking equipment, including systems and components, if built in series, shall be subject to a type test. If not determined differently in another clause of this standard, the tests shall be performed with one single test sample, which is to pass all relevant tests.

If a test is destructive and equivalent results can be achieved by testing individual parts of the equipment, this test may also be performed with a separate test sample or component.

The tests shall be carried out with a test sample ready for operation according to the manufacturer's instructions.

The results and tests shall be recorded in a signed report.

7 Information for use

7.1 Instruction handbook

7.1.1 General

A1 The instruction handbook shall be in accordance with 6.5.1 c), d), e) and g) and 6.5.2 of EN ISO 12100-2:2003. Information as described in 6.5.1 a) and b) of EN ISO 12100-2:2003 shall not normally be supplied. The instruction handbook shall include the duties and conditions under which the equipment is intended to be used, in particular: **A1**

- the vehicles to be handled including an indication of the limiting characteristics, e.g. dimensions, mass;
- operating conditions: e.g. operating hours per day, automatic/manual operation; indication of the operating mode(s);
- range of agreed environmental conditions (e.g. wind, temperature, relative humidity);
- public or non public use.

Details of safety functions and list and location of safety devices shall be provided.

The instruction handbook shall contain information on prohibited applications such as

man riding on movable parts of the equipment other than authorised persons under specific conditions.

The instruction handbook should emphasise the fact that:

- a) the opinion of the manufacturer or his authorised representative should be sought before modifying the design or configuration of the equipment;
- b) the need after modification of the design or configuration of the equipment for re-commissioning to be carried out in accordance with the manufacturer's instructions.

7.1.2 Instructions for the installation of the equipment

7.1.2.1 Details concerning the transmission of forces/torques into the supporting structure, shall be provided by the manufacturer.

7.1.2.2 Lighting

Details concerning the lighting in the transfer area and other areas of the equipment accessible to users shall be provided by the manufacturer. The working area, the transfer area, the user's position, the attendant's position and adjacent areas shall have lighting to enable operations to be carried out safely (see EN 1837).

The lighting system shall be protected from shocks and risk of falling; particular care shall be taken to prevent any fragments from shattered lamps from falling onto persons.

Emergency lighting (e.g. emergency aisle lighting, a torch) shall be provided to enable persons to leave safely.

7.1.2.3 Detailed information as follows, shall be supplied if final assembly and installation are not carried out by the manufacturer:

- assembly and installation;
- special requirements for storage;
- maximum mass, dimensions and lifting points of the separate components supplied;
- methods for safe handling of the components;
- assembly phases;
- handling methods required;
- free space necessary around equipment;
- means to ensure stability during assembly;
- electric and hydraulic installation;
- earth bonding requirements;
- special equipment for assembly/erection and settings;
- safety instructions to be followed if hazardous materials are to be used for the installation of the machinery, its equipment or fixings (e.g. paint, lubricants, sealing materials, insulation, hydraulic fluid);
- testing and commissioning;
- details of fencing where needed.

7.1.3 Instructions for the use of the equipment

7.1.3.1 Operating instructions

The instruction handbook shall include, **A1** in addition to 6.5.1 c) and d) of EN ISO 12100-2:2003 **A1**, the following information for safe operation of the parking system:

- range of application of the equipment;
- how to use the parking system;
- conduct in the event of malfunction;
- that only authorised personnel shall interfere with the normal working of the equipment.
- the stopping modes and means. This shall include instructions to be given to users concerning all normal and emergency stopping devices.
- all areas shall be kept clear of obstacles and rubbish.
- to avoid over-loading;
- instructions about visual verification of the vehicle positioning;

A1

- the operating method to be followed in the event of accident or breakdown. This includes:
 - i. determining the cause of the emergency or accidental stoppage;
 - ii. if necessary repairing the fault. **A1**

The instruction handbook shall state the responsibilities of the user and/or operating company.

7.1.3.2 Abbreviated operating instructions

The instruction handbook shall include the following abbreviated version of the operating instructions:

- a) details of the maximum permissible dimensions and permissible mass of the vehicles to be parked (drawing is recommended);
- b) parked vehicles shall be secured against accidental movements in accordance with the parking equipment manufacturer's operating instructions;
- c) when leaving the parking equipment the control devices shall be secured against unauthorised operation;
- d) travelling with the load carrier is prohibited;
- e) climbing up to a raised vehicle is prohibited;
- f) load carriers shall always be moved vertically to an access position;
- g) work on or under vehicles on load carriers is prohibited;
- h) entry into the pit is prohibited.

Clauses c) and e) to h) do not apply to automatic parking equipment.

7.1.4 Instructions for maintenance

Ⓐ₁ The instruction handbook shall specify in particular [refer to 6.5.1 e) of EN ISO 12100-2:2003]: Ⓐ₁

- a) the technical knowledge and skills of the maintenance staff, especially for operations which need specific competence, that all adjustments, whether mechanical or electrical, shall only be carried out by authorised persons in accordance with a safe system of work and the manufacturer's instructions;
- b) the procedures and conditions under which maintenance works and rectification of faults can be performed e.g. the equipment is isolated, protected against unexpected start-up and measures taken against unexpected movements, e.g. when repair or maintenance of equipment takes place in an area where e.g. a lift, load carrier continues to operate;
- c) a list of wearing parts and the approximate frequency of checking and conditions for their replacement;
- d) a list of parts to be checked periodically including regular checks;
- e) the conditions for examination and replacement of wire ropes, toothed belts and chains;
- f) list of equipment and accessories essential for maintenance. Attention shall be specifically drawn to the obligation of stopping all or part of the equipment to replace certain components;
- g) the need for the equipment to be kept in proper working condition and maintained in accordance with the manufacturer's instructions;
- h) the need for inspection, adjustment, maintenance and cleaning of moving parts and safety devices to be carried out regularly in a safe manner according to the manufacturer's instructions;
- i) how to safely carry out maintenance work where a guard has to be displaced or removed and/or a safety device neutralised;
- j) the need for maintenance of safeguards, warning signs, safety information, markings and lighting;
- k) the appropriate safety instructions if the manufacturer requires harmful materials to be used for the maintenance of the machinery or its equipment (e.g. paint, lubricants, sealing materials, insulation, hydraulic fluid);
- l) specific information for discard of the toothed belt such as 'if a crack is found in the root area of a toothed belt, the belt should be immediately replaced'.

7.1.5 Training

- a) Where the training of parking equipment attendants has been deemed necessary the programme of this training shall be included in the instructions.
- b) Where the training of users has been deemed necessary the programme of this training shall be included in the instructions.

7.2 Marking

7.2.1 The following shall be legibly and indelibly affixed on all types of parking equipment (see EN 61310-2):

NOTE LC indicates that this shall be marked on the load carrier, TA indicates that this shall be marked in the transfer area, WA indicates that this shall be marked in the working area, CS indicates that this shall be marked at the control station.

- a) the rated load in kg or t; (LC{non automatic systems} or TA {automatic systems})
- b) the permissible load distribution if the rated load depends on it; (LC {non automatic systems} or TA {automatic systems})

EN 14010:2003+A1:2009 (E)

- c) a warning sign, (e.g. pictogram) 'carrying of persons is not permitted'; (TA)
- d) a warning sign, (e.g. pictogram) 'carrying of dangerous materials is not permitted'; (TA; CS)
- e) hydraulic supply information if an external hydraulic power supply is used; (WA)
- f) electrical supply information if an external electrical power supply is used; (WA)
- g) fluid reservoirs shall be marked legibly and indelibly with at least the serial number, the year of construction, designation of series or type of system, working pressure and details of the correct type of hydraulic fluid. Where there are several fluid reservoirs, it shall also be clearly indicated which units are served by each fluid reservoir; (WA)
- h) if gas loaded accumulators are provided they shall be marked in accordance with 5.3.4.5 of EN 982:1996; (WA)
- i) where there are several power sources supplying several parking units each power source shall be marked with a means of identifying which parking units are supplied. In addition, each parking unit shall be marked with the power source which it is supplied by; (WA)
- j) the abbreviated operating instructions should be near to any control device intended for the user of the parking system.

7.2.2 The following details shall be indelibly and visibly affixed to each power driven parking equipment using one or more permanent nameplates (see EN 61310-2).

A1

- a) the business name and full address of the manufacturer and, where applicable, his authorized representative; **A1**
- b) country of manufacture;

A1

- c) designation of the machinery; **A1**
- d) serial or works number;
- e) year of installation;
- f) carrying capacity in kg per parking space;
- g) component test mark, if manufactured in compliance with a type-tested prototype;
- h) maximum permissible number of vehicles;
- i) parked vehicles shall be secured against accidental movements in accordance with the parking equipment manufacturer's operating instructions.

Annex A (normative)

Design criteria

The following design criteria shall generally be taken into account when designing or specifying power driven parking equipment:

- a) Rated load min 2.000 kg and max 2.500 kg;
- b) Axle loads: 50 % in each case of the rated load;
- c) Wheel loads: 25 % in each case of the rated load;
- d) Wheelbase: 2,90 m;
- e) Wheel track width: 1,5 m;
- f) Contact surface of the tyre: 0,18 m x 0,18 m;
- g) Forces in direction of travel: 1/7 of the rated load expressed in daN;
- h) Forces orthogonal to the direction of travel: 1/20 of the rated load expressed in daN.

This does not preclude other design criteria.

The most unfavourable stresses due to the position of the vehicle on the load carrier, as well as driving onto the load carrier if this generates greater stresses, shall be taken into account when designing or specifying parking systems.

Annex B
(informative)

Automatic parking equipment

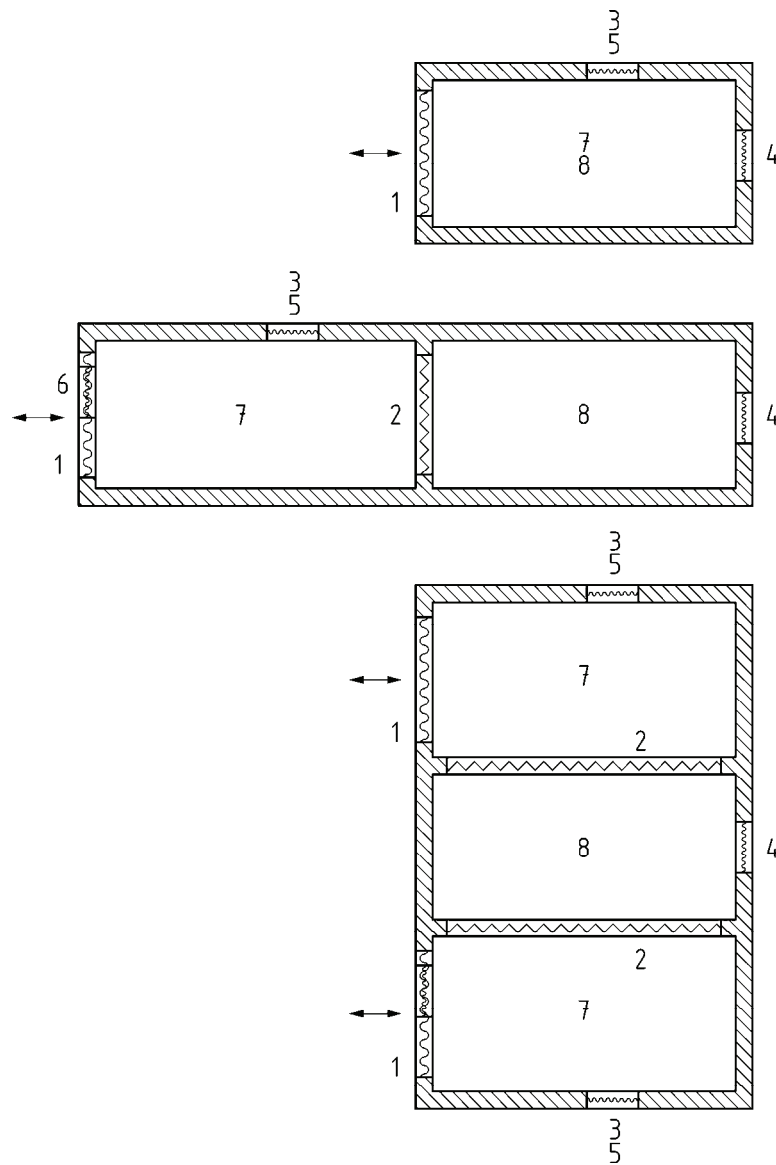

Key

- 1 Main door
- 2 Working area door
- 3 Side door
- 4 Service door
- 5 Emergency door
- 6 Pass door
- 7 Transfer door
- 8 Working area

Figure B.1 – Automatic parking equipment

Annex C
(normative)

Design criteria

All dimensions in meters

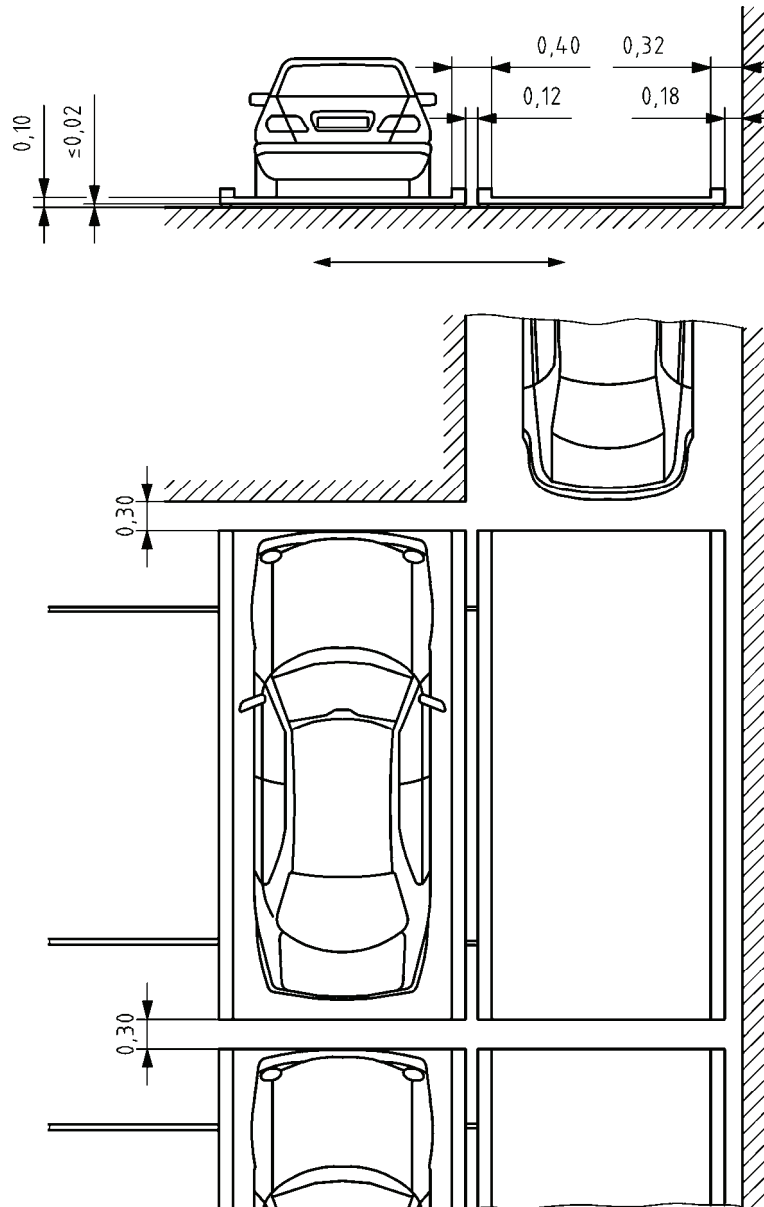

Figure C.1 – Safety distances in accordance with 5.8.4.1

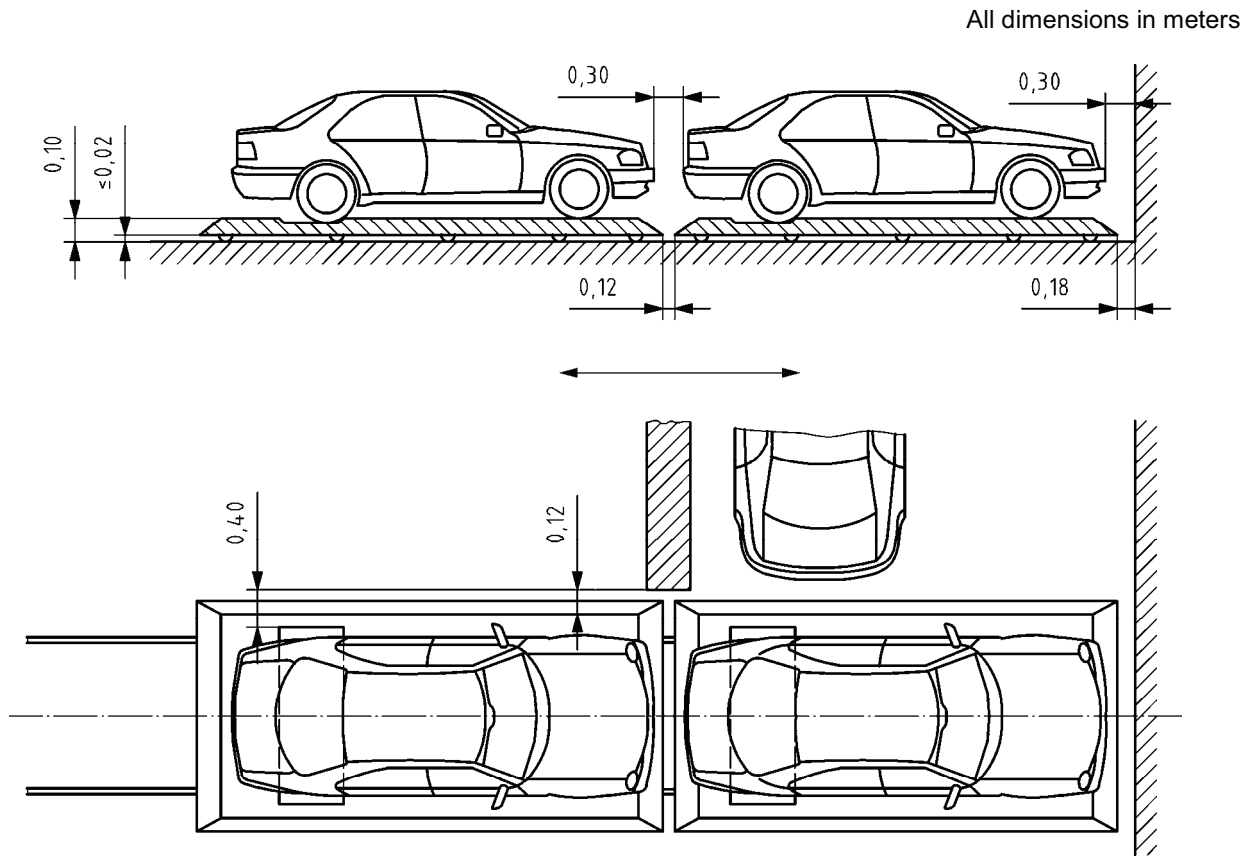

Figure C.2 – Safety distances in accordance with 5.8.4.2

Annex ZA (informative)

A1 Relationship between this European Standard and the Essential Requirements of EU Directive 98/37/EC

This European Standard has been prepared under a mandate given to CEN by the European Commission and the European Free Trade Association to provide a means of conforming to Essential Requirements of the New Approach Directive Machinery 98/37/EC, amended by 98/79/EC.

Once this standard is cited in the Official Journal of the European Communities under that Directive and has been implemented as a national standard in at least one Member State, compliance with the normative clauses of this standard confers, within the limits of the scope of this standard, a presumption of conformity with the relevant Essential Requirements, except ESR 1.5.8 and 1.7.4 f), of that Directive and associated EFTA regulations.

WARNING — Other requirements and other EU Directives may be applicable to the product(s) falling within the scope of this standard. **A1**

Annex ZB
(informative)

Ⓐ Relationship between this European Standard and the Essential Requirements of EU Directive 2006/42/EC

This European Standard has been prepared under a mandate given to CEN by the European Commission and the European Free Trade Association to provide a means of conforming to Essential Requirements of the New Approach Directive Machinery 2006/42/EC.

Once this standard is cited in the Official Journal of the European Communities under that Directive and has been implemented as a national standard in at least one Member State, compliance with the normative clauses of this standard confers, within the limits of the scope of this standard, a presumption of conformity with the relevant Essential Requirements, except ESR 1.5.8 and 1.7.4.2 u), of that Directive and associated EFTA regulations.

WARNING — Other requirements and other EU Directives may be applicable to the product(s) falling within the scope of this standard. Ⓐ

Annex ZC (informative)

A1 Relationship between this European Standard and the Essential Requirements of EU Directive 2004/108/EC

This European Standard has been prepared under a mandate given to CEN by the European Commission and the European Free Trade Association to provide a means of conforming to Essential Requirements of the New Approach Directive Electromagnetic Compatibility 2004/108/EC

Once this standard is cited in the Official Journal of the European Communities under that Directive and has been implemented as a national standard in at least one Member State, compliance with the clauses of this standard given in Table ZC.1 confers, within the limits of the scope of this standard, a presumption of conformity with the corresponding Essential Requirements of that Directive and associated EFTA regulations.

Table ZC.1 — Correspondence between this European Standard and Directive 2004/108/EC

Relevant clauses/sub clauses in this standard	Article of EMC Directive 2004/108/EC
5.2.5.1 – EMC (general aspects)	Annex I Article 1
6.2.1 – EMC Compliance criteria (general aspects)	Annex I Article 1

A1

Bibliography

- [1] EN 81-1:1998, *Safety rules for the construction and installation of lifts – Part 1: Electric lifts*
- [2] EN 81-2:1998, *Safety rules for the construction and installation of lifts – Part 2: Hydraulic lifts*
- [3] EN 280, *Mobile elevating work platforms - Design calculations - Stability criteria - Construction – Safety – Examinations and tests*
- [4] EN 528:1996, *Rail dependent storage and retrieval equipment – Safety*
- [5] EN 547-1, *Safety of machinery – Human body measurements – Part 1: Principles for determining the dimensions required for openings for whole body access into the machinery*
- [6] EN 547-3, *Safety of machinery – Human body measurements – Part 3: Anthropometric data*
- [7] EN 894-1, *Safety of machinery — Ergonomic requirements for the design of displays and control actuators — Part 1: General principles for human interactions with displays and control actuators*
- [8] EN 894-3, *Safety of machinery — Ergonomics requirements for the design of displays and control actuators — Part 3: Control actuators*
- [9] EN 1005 1, *Safety of machinery — Human physical performance — Part 1: Terms and definitions*
- [10] EN 1493, *Vehicle lifts*
- [11] ENV 1991:EUROCODE 1: *Basis of design and actions on structures*
- [12] ENV 1992:EUROCODE 2: *Design of concrete structures*
- [13] ENV 1993:EUROCODE 3: *Design of steel structures*
- [14] EN ISO 12543 1, *Glass in building — Laminated glass and laminated safety glass — Part 1: Definitions and description of component parts (ISO 12543-1:1998)*
- [15] ISO 606:1994, *Short-pitch transmission precision roller chains and chain wheels*
- [16] ISO 2408:1985, *Steel wire ropes for general purposes – Characteristics*
- [17] ISO 4301-1:1986, *Cranes and lifting appliances - Classification. Part 1: General*
- [18] ISO 4301-2:1985, *Lifting appliances - Classification. Part 2: Mobile cranes*
- [19] ISO 4308-1:1986, *Cranes and lifting appliances - Selection of wire ropes – Part 1: General*
- [20] ISO 4308-2:1988, *Cranes and lifting appliances - Selection of wire ropes – Part 2: Mobile cranes - Co-efficient of utilisation*
- [21] AMHSA SC 2, *Safety code for systems utilising storage and retrieval equipment*
- [22] ASS 134, *Staplingskranar*
- [23] DIN 15350, *Regalbediengeräte - Grundsatz für Stahltragwerke – Berechnungen*
- [24] FEM 9.311, *Rules for the design of storage and retrieval machines – Structures*
- [25] FEM 9.661, *Rules for the design of series lifting equipment - Dimensions and design of rope reeving components*

- [26] FEM 9.753, *Safety rules for storage and retrieval machines*
- [27] FEM 9.754, *Safety rules for automatic miniload storage and retrieval machines*
- [28] FEM 9.755, *Measures for achieving safe working periods for motorised serial hoist units (S.W.P.)*
- [29] FEM 9.831, *Calculation principles of storage and retrieval machines - Tolerances, deformations and clearances in the high-bay warehouse*
- [30] ÖN M 9610, *In Schienen oder Führungen laufende Geräte zur Regalbedienung - Bau-, Prüf-, Betriebs- und Wartungsvorschriften*
- [31] ZH1/361, *Richtlinien für Geräte und Anlagen zur Regalbedienung*
- [32] CLC Report No.R044-001:1995, *Safety of machinery — Guidance and recommendations for the avoidance of hazards due to static electricity*

